

**INSTALLATIONS**

HVAC INSTALLATION SOLUTIONS

**Rodigas**<sup>®</sup>  
SRL

A FAMILY COMPANY  
SINCE 1958







# 1958



Since its creation in 1958, our company has been able to read and interpret changes in society, anticipating the evolution of the market and offering solutions in tune with the times. Adaptability and innovation are the keys to the success of Rodigas, which today operates worldwide in the sectors of air conditioning systems, photovoltaic systems and fall protection systems.



“

OUR COMPANY  
HAS GROWN LIKE  
A FAMILY.  
THIS STRATEGY  
HAS ALLOWED US  
TO BECOME A  
EUROPEAN COMPANY.

”

**Dino Roverato**  
Founder of Rodigas

# WE BELIEVE IN PERSONS AND FOR THIS REASON WE INVEST IN THEM

A COMPANY MADE  
UP OF PEOPLE  
CANNOT FAIL TO TAKE  
CARE THE HEALTH  
AND SAFETY OF ITS  
EMPLOYEES.  
IT WAS A NATURAL  
STEP FOR US TO  
CERTIFIED ISO 45001.

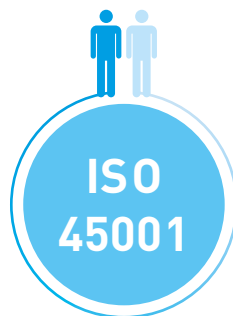

Health and safety  
management systems

We believe that collaboration, respect and culture are fundamental values a company can not dismiss. For this reason we are committed to invest not only in the training of our employees, but also to the creation of a cohesive and reliable work environment, which can guarantee safety and continuity in the workplace and which translates into loyalty to the company.

Crediamo che collaborazione, rispetto e cultura siano valori fondamentali dai quali un'azienda non possa prescindere. È per questa ragione che ci impegniamo a investire non soltanto nella formazione dei nostri collaboratori, ma anche nella creazione di un ambiente di lavoro affiatato e affidabile, che possa garantire sicurezza e continuità nel lavoro e che si traduca in fedeltà all'azienda.



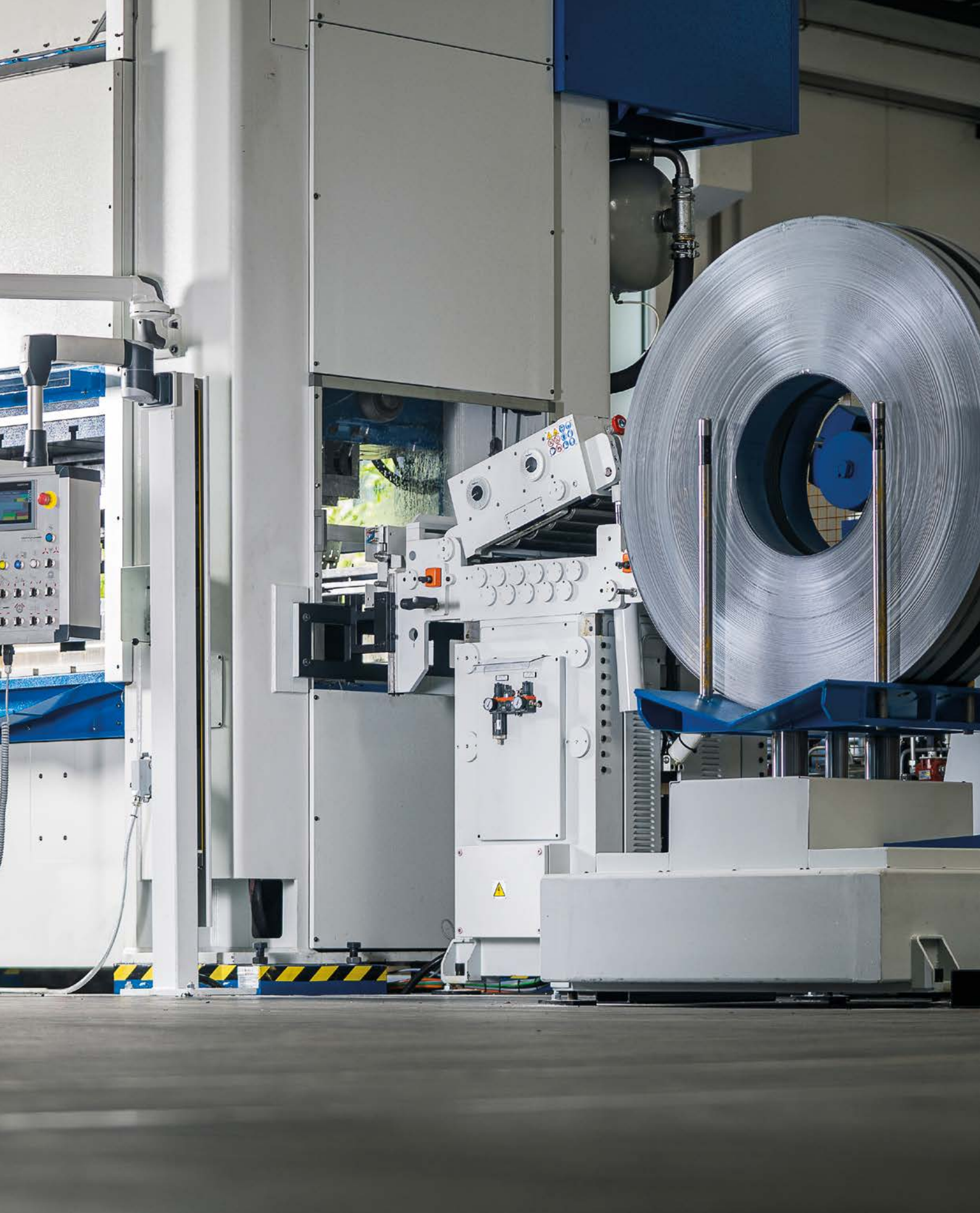

# ENSURING PRODUCT SECURITY AND HIGH QUALITY PRODUCTION STANDARDS ARE OUR FOCUS

## BIM

For us at Rodigas, service is always the first and most important product we offer to our customers. That is why we are concerned about offering highly professional solutions for technical studies and designers who are more responsive to new technology solutions. This is a brilliant example of our Building Information Modeling Libraries (BIM), available to all professionals who want to include Rodigas products for conditioning, photovoltaics and fall protection in their projects.

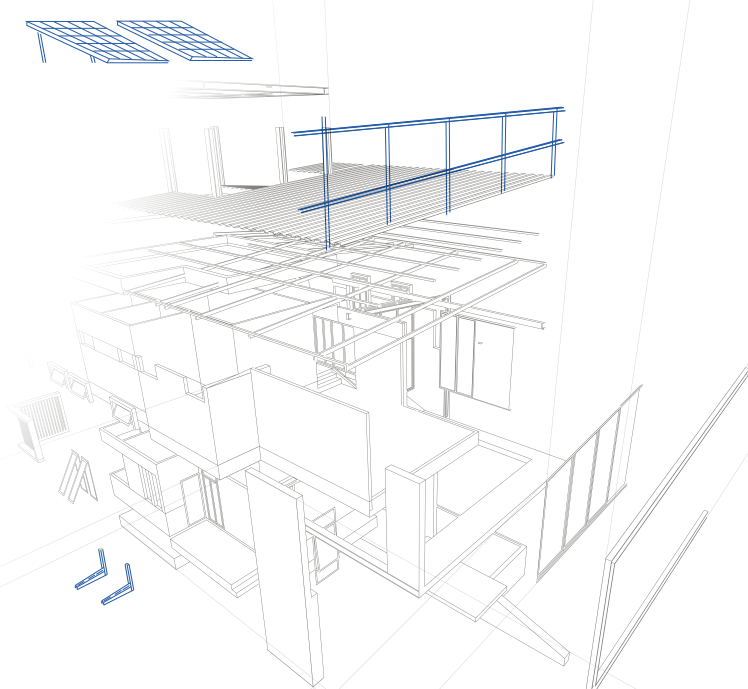



## OUR CERTIFICATIONS

Certified products and processes are the best quality assurance we can offer. It is for this reason that we continuously compare ourselves with accredited institutions and professionals who guide us on our journey.

Rodigas<sup>®</sup>  
S.R.L.

AIPAA<sup>®</sup>

DOLOMITICERT  
TESTING LABORATORY



TÜV  
AUSTRIA



Management System  
ISO 9001:2015



www.tuv.com  
ID 9105073334



Management System  
ISO 14001:2015



www.tuv.com  
ID 9105073334



Management System  
ISO 45001:2018



www.tuv.com  
ID 9105073334

SOCIUNI  
Licenza 0082 del 15/12/2015





Rodigas

# THE FOURTH INDUSTRIAL REVOLUTION

WE WORK TO IMPROVE PRODUCT  
QUALITY, BOOST FACTORY EFFICIENCY,  
STAY COMPETITIVE, ENHANCE SAFETY,  
SECURITY AND THE SUSTAINABILITY OF  
OUR PROCESSES.



# TECHNOLOGY DIGITAL IS THE NEW MOTOR OF OUR GROWTH

THE ARTISAN ORIGIN OF  
RODIGAS LIVES IN THE FACES  
AND GESTURES OF PEOPLE  
WHO HAVE SET THE BASIS  
OF THE COMPANY



Faces that are the mirror of a metalworking tradition and that, knowing how to replace the “tools of the trade” at the right time, have built the company’s future by learning to manage that technology which today allows us to operate with cutting-edge machinery and software.



QUALITY  
STARTING  
FROM EXPERT  
PEOPLE





Our quality management team carries out strict inspection and testing procedures throughout the entire development and production process. Thus we assure a constant quality in performance and in the products, for the best of the customers.

Il nostro team di gestione della qualità esegue rigorose ispezioni e collaudi durante tutto il processo di produzione. In questo modo possiamo garantire una qualità costante nelle prestazioni e nel prodotto.



4

persone dedicate al controllo qualità  
people employed in quality control



80

ore dedicate a test e controlli ogni settimana  
hours dedicated to testing and inspection every week



100%

controlli automatici in linea di produzione  
automatic controls in production line

## FALL PROTECTION SYSTEMS

From the experience gained in the field of renewable energy, we have developed solutions for the safety of operators working at height.



Fall protection systems and parapets are the right answer to security on building sites and during maintenance of buildings and systems.

## STRUCTURES FOR PHOTOVOLTAIC PLANTS

Our attention to the environment and to new energy sources has seen us engaged for over ten years in the photovoltaic energy sector.



We have consolidated skills regarding the design, verification and production of structures for installing photovoltaic modules.



## PRODUCTION

Introduction Introduzione	04
Sliding brackets Mensole scorrevoli	16
Folding brackets Mensole pieghevoli	50
Welded brackets Mensole saldate	58
Roof brackets Mensole da tetto	78
Special brackets Mensole speciali	84
Floor supports Supporti pavimento	94

## DISTRIBUTION

Vibration dampers Antivibranti	104
Condensate drainage set Scarico condensa	108
Ducts Canaline	128
Other products Altri prodotti	134
Frame Foot™ Support	144

A grayscale close-up photograph of a mechanical assembly, possibly a printer or scanner. The image shows various components like rollers, gears, and a spring mechanism. A red text overlay 'SLI' is positioned in the upper right quadrant.

SLI

# DING

## SLIDING BRACKETS

- Sliding
- Frontal hook
- Crossbar

## MENSOLE SCORREVOLI

- Scorrevole
- Aggancio frontale
- Barra a muro

Rodigas<sup>®</sup>  
SRL 



# WE HAVE DESIGNED AN EASY SOLUTION FOR EASY MACHINES



## ITALIANO

### MENSOLA SCORREVOLE EASY ANONIMA

Ultima nata della famiglia Rodigas, la serie easy si posiziona sulla fascia di prodotti entry level.

Abbiamo sviluppato questo prodotto mantenendo inalterata la qualità della produzione e dei materiali, ma grazie alla peculiarità del sistema costruttivo, siamo riusciti a ridurre notevolmente la quantità di materiale utilizzato per la sua realizzazione, garantendo una portata di 120 kg sia sulla dimensione di braccio 450mm che sulla 550mm.

Questi nuovi prodotti creano una spaccatura evidente con le classiche linee Rodigas e si pongono come alternativa commerciale laddove la clientela richieda prodotti più semplici.

## ENGLISH

### EASY SLIDING BRACKET- UNBRANDED

Easy series is the latest addition TO Rodigas's Family and is positioned in the entry level product range.

We have developed this product while maintaining the quality of production and materials. Thanks to the peculiarity of the construction system, we have managed to considerably reduce the quantity of material used in its manufacture, guaranteeing a load capacity of 120 kg on both the 450mm and 550mm arm sizes.

These new products create an evident break with the classic Rodigas branded lines and they could be a commercial alternative where less exigent customers require simpler products.

## FRANCE

### EASY CHASSIS COULISSANT ANONYME

La série Easy est la dernière née de la famille Rodigas et se positionne dans l'entrée de gamme des produits.

Nous avons développé ce produit tout en maintenant la qualité de la production et des matériaux. Grâce à la particularité du système de construction, nous avons réussi à réduire considérablement la quantité de matériaux utilisés dans sa fabrication, garantissant une capacité de charge de 120 kg sur les bras de 450 mm et 550 mm.

Ces nouveaux produits créent une rupture nette avec les lignes classiques de la marque Rodigas et pourraient constituer une alternative commerciale lorsque des clients moins exigeants demandent des produits plus simples.



Management System  
ISO 9001:2015  
ISO 14001:2015  
ISO 45001:2018  
www.towersperrin.com  
tel: 9162075334







# MS EASY

## ENTRY LEVEL SUPPORT

### SLIDING BRACKETS

- ▶ Sliding
- Frontal hook
- Crossbar

### MENSOLE SCORREVOLI

- ▶ Scorrevole
- Aggancio frontale
- Barra a muro



### MATERIALS AND TREATMENT

- Materials:** electro-galvanised steel plate
- Treatment:** painting epoxy resins in polyester
- Colour:** Ral 9002
- Joint:** 2 high resistant screw M6x55 8.8
- Adjustment:** 2 adjustable gummy polypropilene feet (patented)
- Equipped with:** level to adjust the wall bar

### LOAD CAPACITY

- Load capacity:** 120 kg
- Load testing weight:** 300 kg

### PACKAGING MS EASY 450

- Pack:** carton box
- Pieces:** 1
- Pack dimensions:** 90x65x800 mm
- Case weight:** 2,6 kg
- Pallet dimensions:** 120 x80 x100 cm
- Pieces per pallet:** 156
- Pallet total weight:** 425 kg

### MS EASY 450

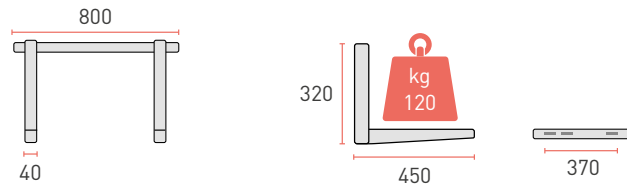

### BRACKET DRILLING DIAGRAM

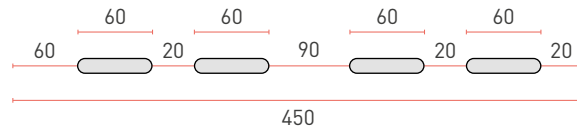

### MS EASY 550

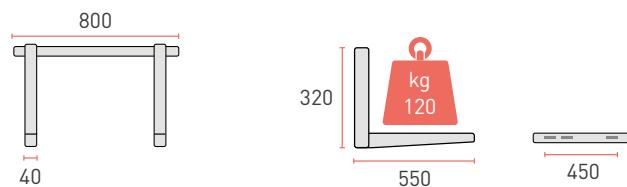

### BRACKET DRILLING DIAGRAM

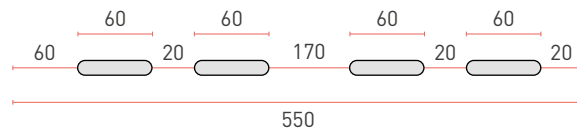



# OUR CERTIFICATIONS

Certified products and processes are the best quality assurance we can offer. It is for this reason that we continuously compare ourselves with accredited institutions and professionals who guide us on our journey.

## MS EASY 450 FOLDABLE

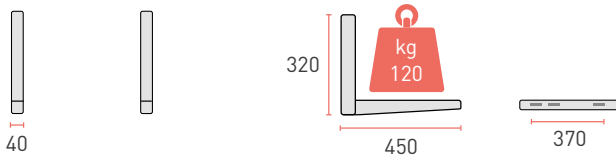

### BRACKET DRILLING DIAGRAM

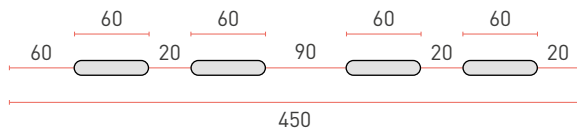

## MS EASY 550 FOLDABLE

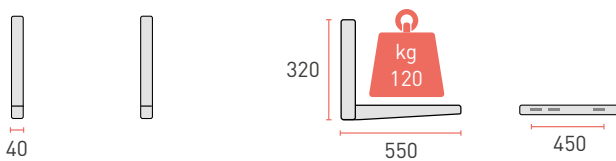

### BRACKET DRILLING DIAGRAM

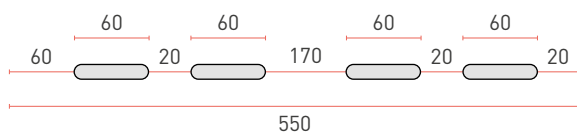

Management System  
ISO 9001:2015

www.tuv.com  
ID: 9105073334



Management System  
ISO 14001:2015

www.tuv.com  
ID: 9105073334



Management System  
ISO 45001:2018

www.tuv.com  
ID: 9105073334



# MS 230

## SLIDING BRACKETS

- ▶ Sliding
- Frontal hook
- Crossbar

## MENSOLE SCORREVOLI

- ▶ Scorrevole
- Aggancio frontale
- Barra a muro



## MATERIALS AND TREATMENT

**Materials:** electro-galvanised steel plate

**Treatment:** painting epoxy resins in polyester

**Colour:** Ral 9002

**Joint:** high resistant screw M6×70 8.8

**Adjustment:** 2 adjustable gummy polypropilene feet (patented)

**Equipped with:** level to adjust the wall bar, wall fixing kit, insulating washers

## LOAD CAPACITY

**Domestic use:** 140 kg

**Load testing weight:** 420 kg

## DIMENSIONS AND LOADING CAPACITY

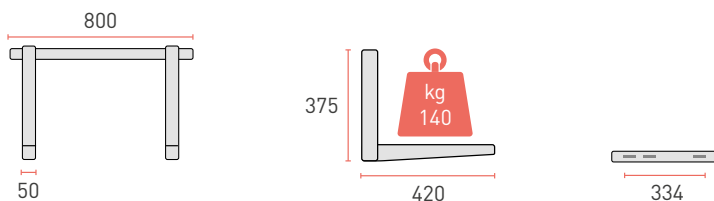

## BRACKET DRILLING DIAGRAM

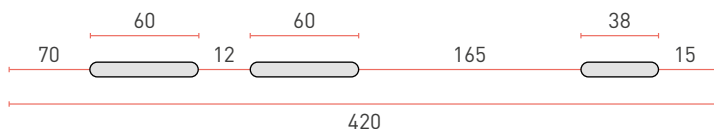

## BOX

**Pack:** carton box

**Pieces:** 1

**Pack dimensions:** 90×95×800 mm

**Case weight:** 3.5 kg

## PALLET

**Pallet dimensions:** 120×80×100 cm

**Pieces per pallet:** 117

**Pallet total weight:** 420 kg

Adjustable rear foot



Insulating washers



Wall fixing kit



Levelling system



Certified quality



### DIMENSIONS AND LOADING CAPACITY

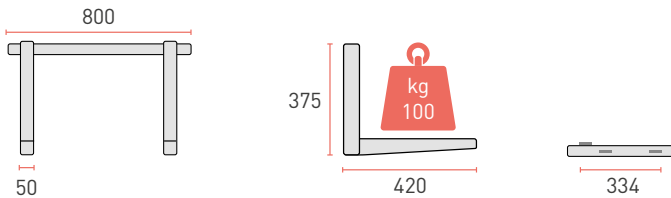

### BRACKET DRILLING DIAGRAM

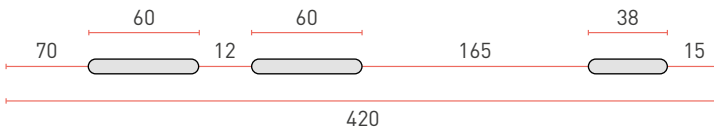

Adjustable rear foot



Insulating washers



Wall fixing kit



Levelling system



# MS 901

## SLIDING BRACKETS

- ▶ Sliding
- Frontal hook
- Crossbar

## MENSOLE SCORREVOLI

- ▶ Scorrevole
- Aggancio frontale
- Barra a muro

## MATERIALS AND TREATMENT

**Materials:** electro-galvanised steel plate

**Treatment:** painting epoxy resins in polyester

**Colour:** Ral 9002

**Joint:** high resistant screw M6×70 8.8

**Adjustment:** 2 adjustable gummy polypropilene feet (patented)

**Equipped with:** level to adjust the wall bar, wall fixing kit, insulating washers

## LOAD CAPACITY

**Domestic use:** 100 kg

**Load testing weight:** 300 kg

## BOX

**Pack:** carton box

**Pieces:** 1

**Pack dimensions:** 90×95×610 mm

**Case weight:** 3.5 kg

## PALLET

**Pallet dimensions:** 120×80×100 cm

**Pieces per pallet:** 117

**Pallet total weight:** 600 kg



# MS 242 - MS 243

## SLIDING BRACKETS

- ▶ Sliding
  - Frontal hook
  - Crossbar

## MENSOLE SCORREVOLI

- ▶ Scorrevole
  - Aggancio frontale
  - Barra a muro

## MATERIALS AND TREATMENT

**Materials:** electro-galvanised steel plate

**Treatment:** painting epoxy resins in polyester

**Colour:** Ral 9002

**Joint:** high resistant screw M6×70 8.8

**Adjustment:** 2 adjustable gummy polypropilene feet (patented)

## LOAD CAPACITY

**Domestic use:** 140 kg

**Load testing weight:** 420 kg

## BOX

**Pack:** carton box

**Pieces:** 1

**Pack dimensions:** 90×95×800 mm

**Case weight:** 4.2 kg

## PALLET

**Pallet dimensions:** 120×80×100 cm

**Pieces per pallet:** 117

**Pallet total weight:** 500 kg



## DIMENSIONS AND LOADING CAPACITY

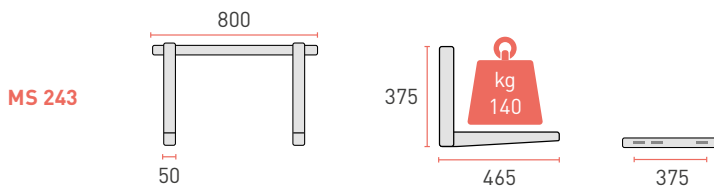
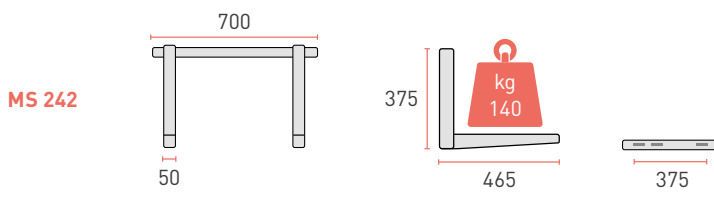

## BRACKET DRILLING DIAGRAM

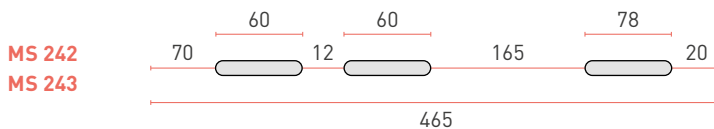

Adjustable rear foot



Wall fixing kit



Insulating washers



Pre assembled



Certified quality

# MS 244 - MS 245



## SLIDING BRACKETS

- ▶ Sliding
- Frontal hook
- Crossbar

## MENSOLE SCORREVOLI

- ▶ Scorrevole
- Aggancio frontale
- Barra a muro

## MATERIALS AND TREATMENT

**Materials:** electro-galvanised steel plate

**Treatment:** painting epoxy resins in polyester

**Colour:** Ral 9002

**Joint:** high resistant screw M6×70 8.8

**Adjustment:** 2 adjustable gummy polypropilene feet (patented)

## DIMENSIONS AND LOADING CAPACITY

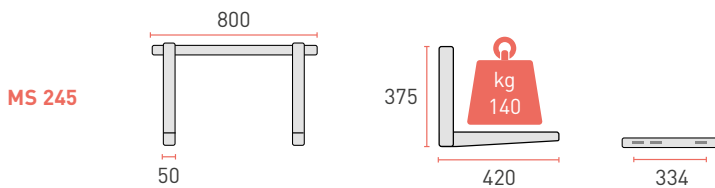
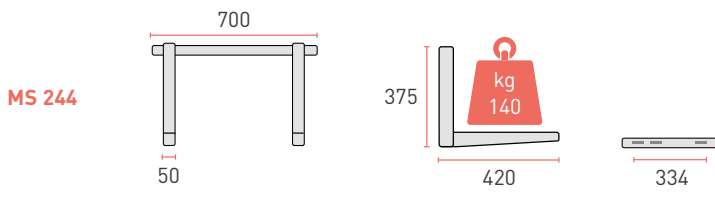

## LOAD CAPACITY

**Domestic use:** 140 kg

**Load testing weight:** 420 kg

## BRACKET DRILLING DIAGRAM

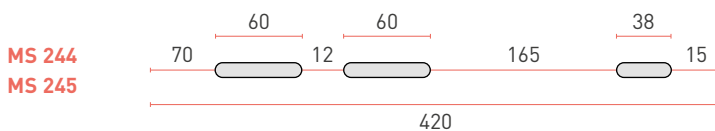

## BOX

**Pack:** carton box

**Pieces:** 1

**Pack dimensions:** 90×95×800 mm

**Case weight:** 4.2 kg

## PALLET

**Pallet dimensions:** 120×80×100 cm

**Pieces per pallet:** 117

**Pallet total weight:** 500 kg



Adjustable rear foot



Wall fixing kit



Insulating washers



Pre assembled



Certified quality



# WE ARE YOUR PARTNER FOR HVAC INSTALLATION, PHOTOVOLTAIC AND ANTI FALL SYSTEMS

## OUR VISION

Our experience in different sectors means that we can combine solutions from all three of our divisions: air conditioning, photovoltaic systems, and fall protection systems.

Let's take a concrete example: in the event that a traditional system is replaced with a heat pump system in a building (something that is becoming increasingly common in new buildings, where high energy standards are required), we can supply, among other things, supports and brackets for fitting external air conditioner units. Heating, cooling, and producing domestic hot water using heat pumps brings considerable advantages in economic and environmental terms, replacing natural gas with electricity. However, in order for the system to be truly sustainable it is essential that the energy is produced on-site, using a photovoltaic system. Thanks to our experience in the sector, we can also help our customers in the choice and design of brackets and fittings for the installation of a photovoltaic system. In turn, this will require the installation of a fall protection system, which we can also help with.

Discover our completely range on [www.rodigas.it](http://www.rodigas.it)





# MS 246 - MS 247

## SLIDING BRACKETS

- ▶ Sliding
  - Frontal hook
  - Crossbar

## MENSOLE SCORREVOLI

- ▶ Scorrevole
  - Aggancio frontale
  - Barra a muro

## MATERIALS AND TREATMENT

**Materials:** electro-galvanised steel plate

**Treatment:** painting epoxy resins in polyester

**Colour:** Ral 9002

**Joint:** high resistant screw M6×70 8.8

**Adjustment:** 2 adjustable gummy polypropilene feet (patented)

## LOAD CAPACITY

**Domestic use:** 140 kg

**Load testing weight:** 420 kg

## BOX

**Pack:** carton box

**Pieces:** 1

**Pack dimensions:** 90×95×800 mm

**Case weight:** 4.2 kg

## PALLET

**Pallet dimensions:** 120×80×100 cm

**Pieces per pallet:** 117

**Pallet total weight:** 500 kg



## DIMENSIONS AND LOADING CAPACITY

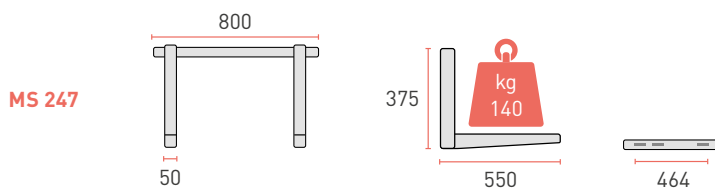
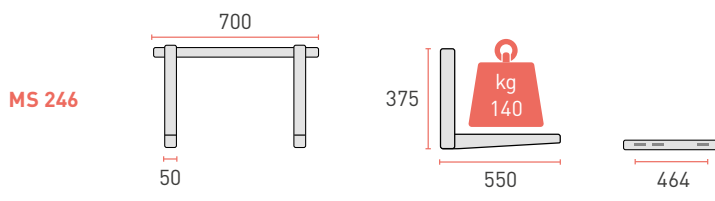

## BRACKET DRILLING DIAGRAM

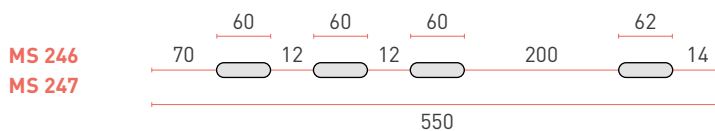

Adjustable rear foot



Wall fixing kit



Insulating washers



Pre assembled



Certified quality



# MS 252 - MS 253



## SLIDING BRACKETS

- ▶ Sliding
  - Frontal hook
  - Crossbar

## MENSOLE SCORREVOLI

- ▶ Scorrevole
  - Aggancio frontale
  - Barra a muro

## DIMENSIONS AND LOADING CAPACITY

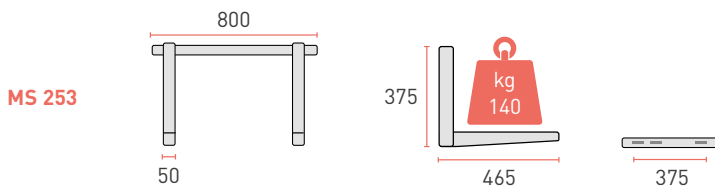
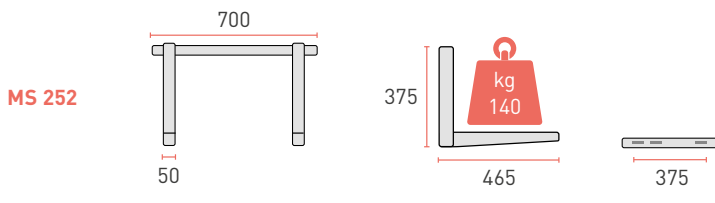

## BRACKET DRILLING DIAGRAM

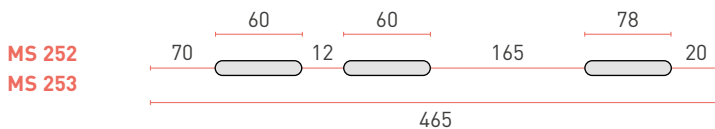

Adjustable rear foot



Wall fixing kit



Insulating washers



Pre assembled

## MATERIALS AND TREATMENT

**Materials:** electro-galvanised steel plate

**Treatment:** painting epoxy resins in polyester

**Colour:** Ral 9002

**Joint:** high resistant screw M6×70 8.8

**Adjustment:** 2 adjustable gummy polypropilene feet (patented)

**Equipped with:** level to adjust the wall bar

## LOAD CAPACITY

**Domestic use:** 140 kg

**Load testing weight:** 420 kg

## BOX

**Pack:** carton box

**Pieces:** 1

**Pack dimensions:** 90×95×800 mm

**Case weight:** 4.2 kg

## PALLET

**Pallet dimensions:** 120×80×100 cm

**Pieces per pallet:** 117

**Pallet total weight:** 500 kg



Certified quality

# MS 254 - MS 255

## SLIDING BRACKETS

- ▶ Sliding
  - Frontal hook
  - Crossbar

## MENSOLE SCORREVOLI

- ▶ Scorrevole
  - Aggancio frontale
  - Barra a muro

## MATERIALS AND TREATMENT

**Materials:** electro-galvanised steel plate

**Treatment:** painting epoxy resins in polyester

**Colour:** Ral 9002

**Joint:** high resistant screw M6×70 8.8

**Adjustment:** 2 adjustable gummy polypropilene feet (patented)

**Equipped with:** level to adjust the wall bar

## LOAD CAPACITY

**Domestic use:** 140 kg

**Load testing weight:** 420 kg

## BOX

**Pack:** carton box

**Pieces:** 1

**Pack dimensions:** 90×95×800 mm

**Case weight:** 4.2 kg

## PALLET

**Pallet dimensions:** 120×80×100 cm

**Pieces per pallet:** 117

**Pallet total weight:** 500 kg



## DIMENSIONS AND LOADING CAPACITY

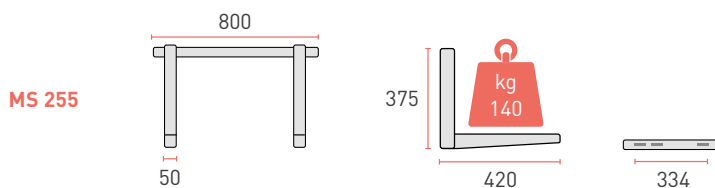
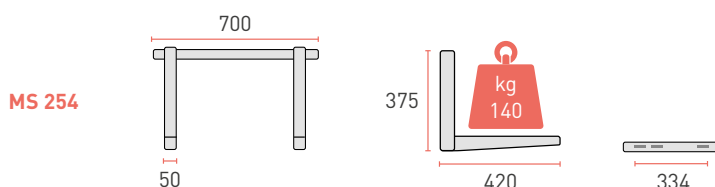

## BRACKET DRILLING DIAGRAM

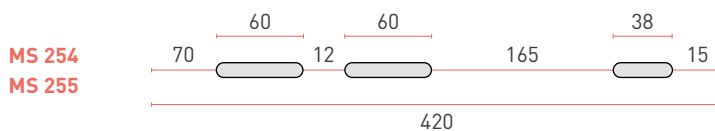

Adjustable rear foot



Wall fixing kit



Insulating washers



Pre assembled



Certified quality

# MS 256 - MS 257



## SLIDING BRACKETS

- ▶ Sliding
  - Frontal hook
  - Crossbar

## MENSOLE SCORREVOLI

- ▶ Scorrevole
  - Aggancio frontale
  - Barra a muro

## DIMENSIONS AND LOADING CAPACITY

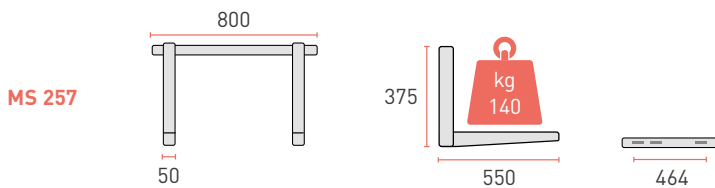
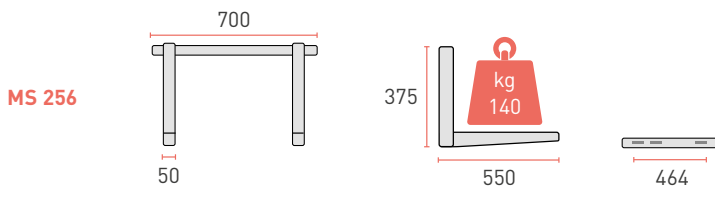

## BRACKET DRILLING DIAGRAM

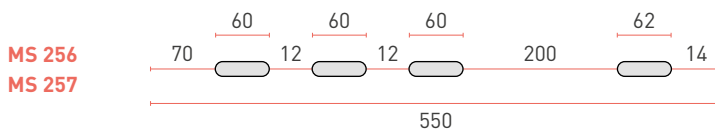

Adjustable rear foot



Wall fixing kit



Insulating washers



Pre assembled

## MATERIALS AND TREATMENT

**Materials:** electro-galvanised steel plate

**Treatment:** painting epoxy resins in polyester

**Colour:** Ral 9002

**Joint:** high resistant screw M6×70 8.8

**Adjustment:** 2 adjustable gummy polypropilene feet (patented)

**Equipped with:** level to adjust the wall bar

## LOAD CAPACITY

**Domestic use:** 140 kg

**Load testing weight:** 420 kg

## BOX

**Pack:** carton box

**Pieces:** 1

**Pack dimensions:** 90×95×800 mm

**Case weight:** 4.2 kg

## PALLET

**Pallet dimensions:** 120×80×100 cm

**Pieces per pallet:** 117

**Pallet total weight:** 500 kg



Certified quality

# WE MADE NEW 650 MM ARMS FOR A PERFECT INSTALLATION

## MS 258N SLIDING BRACKET

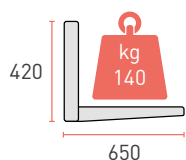
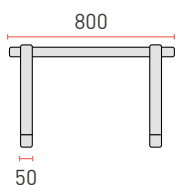

### BRACKET DRILLING DIAGRAM

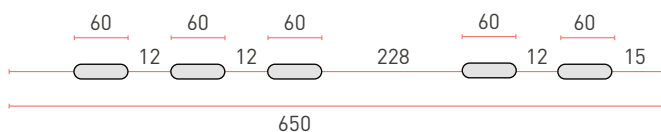

Adjustable rear foot



Wall fixing kit



Insulating washers



Pre assembled



Levelling system







## MATERIALS AND TREATMENT

**Materials:** electro-galvanised steel plate

**Treatment:** painting epoxy resins in polyester

**Colour:** Ral 9002

**Joint:** 2 high resistant screw M6x70 8.8

**Adjustment:** 2 adjustable gummy polypropilene feet (patented)

**Equipped with:** level to adjust the wall bar

## LOAD CAPACITY

**Load capacity:** 140 kg

**Load testing weight:** 420 kg

## PACKAGING

**Pack:** carton box **Pieces:** 1

**Pack dimensions:** 90x95x1060 mm

**Case weight:** 6.4 kg

**Pallet dimensions:** 106 x 106 x 100 cm

**Pieces per pallet:** 108

**Pallet total weight:** 690 kg

## OUR CERTIFICATIONS

Certified products and processes are the best quality assurance we can offer. It is for this reason that we continuously compare ourselves with accredited institutions and professionals who guide us on our journey.

Rodigas<sup>®</sup>  
BRL

AIPAA<sup>®</sup>

DOLOMITICERT  
TESTING LABORATORY



TUV  
AUSTRIA



Management System  
ISO 9001:2015  
www.tuv.com  
ID: 9105073334



Management System  
ISO 14001:2015  
www.tuv.com  
ID: 9105073334



Management System  
ISO 45001:2018  
www.tuv.com  
ID: 9105073334



SOCIUNI  
Licenza 0082 del 15/12/2015

# OUR BLACK BRACKET IT'S COOL AND FITS PERFECT WITH YOUR MACHINE

## MS 253N SLIDING BRACKET

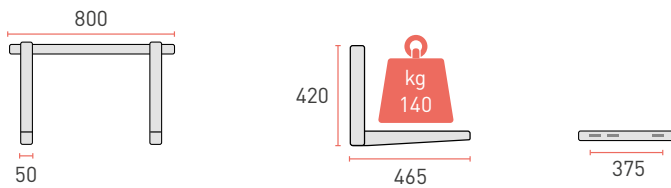

### BRACKET DRILLING DIAGRAM

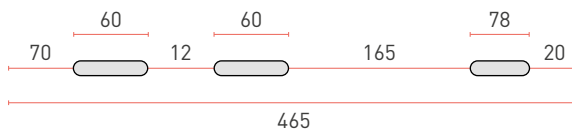

## MS 257N SLIDING BRACKET

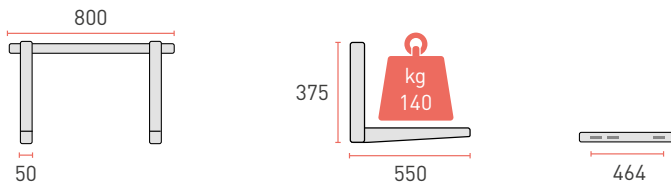

### BRACKET DRILLING DIAGRAM

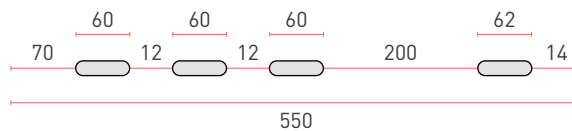

Adjustable  
rear foot



Wall  
fixing kit



Insulating  
washers



Pre  
assembled



Levelling  
system





## OUR CERTIFICATIONS

Certified products and processes are the best quality assurance we can offer. It is for this reason that we continuously compare ourselves with accredited institutions and professionals who guide us on our journey.



### MATERIALS AND TREATMENT

**Materials:** electro-galvanised steel plate

**Treatment:** painting epoxy resins in polyester

**Colour:** Ral 7016 matt

**Joint:** 2 high resistant screw M6x70 8.8

**Adjustment:** 2 adjustable gummy polypropilene feet (patented)

**Equipped with:** level to adjust the wall bar

### LOAD CAPACITY

**Load capacity:** 140 kg

**Load testing weight:** 420 kg

Rodigas<sup>®</sup>  
BRL

AIPAA

DOLOMITICERT  
TESTING LABORATORY



TUV  
AUSTRIA



Management System  
ISO 9001:2015



www.tuv.com  
ID: 9105073334



Management System  
ISO 14001:2015



www.tuv.com  
ID: 9105073334



Management System  
ISO 45001:2018



www.tuv.com  
ID: 9105073334

SOCIUNI  
Licenza 0082 del 15/12/2015

# MS 263

INOX



## SLIDING BRACKETS

- ▶ Sliding
- Frontal hook
- Crossbar

## MENSOLE SCORREVOLI

- ▶ Scorrevole
- Aggancio frontale
- Barra a muro

## MATERIALS AND TREATMENT

**Materials:** AISI 304 stainless steel plate

**Treatment:** epoxy resins in polyester on request

**Colour:** Natural/Ral 7035

**Joint:** high resistant screw M6x70 8.8

**Adjustment:** 2 adjustable gummy polypropilene feet

## LOAD CAPACITY

**Domestic use:** 140 kg

**Load testing weight:** 420 kg

## DIMENSIONS AND LOADING CAPACITY

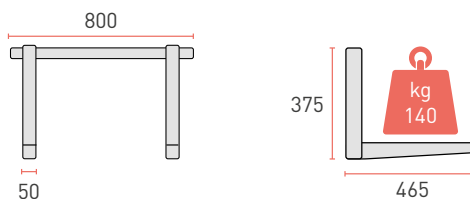

## BRACKET DRILLING DIAGRAM

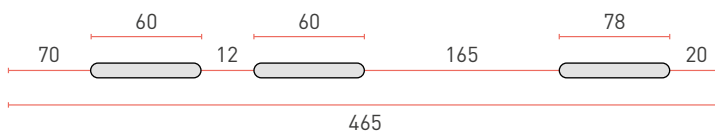

## BOX

**Pack:** carton box

**Pieces:** 1

**Pack dimensions:** 90x95x800 mm

**Case weight:** 4.2 kg

## PALLET

**Pallet dimensions:** 120x80x100 cm

**Pieces per pallet:** 117

**Pallet total weight:** 500 kg

Insulating washers



Levelling system



Wall fixing kit



Pre assembled



Certified quality



# MS 213 - MS 214



## SLIDING BRACKETS

- Sliding
- ▶ Frontal hook
- Crossbar

## MENSOLE SCORREVOLI

- Scorrevole
- ▶ Aggancio frontale
- Barra a muro

## DIMENSIONS AND LOADING CAPACITY

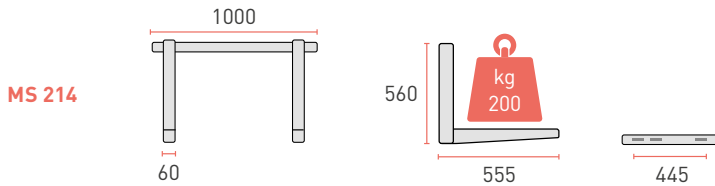
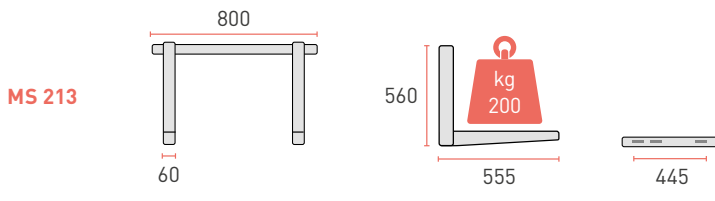

## BRACKET DRILLING DIAGRAM

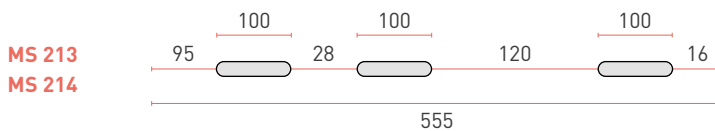

Adjustable rear foot



Wall fixing kit



Insulating washers



Levelling system

## MATERIALS AND TREATMENT

**Materials:** electro-galvanised steel plate

**Horizontal rod material:** aluminium alloy

**Treatment:** epoxy resins in polyester for outdoor

**Colour:** Ral 9002

**Joint:** high resistant screw M8×80 8.8

**Adjustment:** 4 adjustable gummy polypropilene feet (patented)

## LOAD CAPACITY

**Domestic use:** 200 kg

**Load testing weight:** 600 kg

## BOX

**Pack:** carton box

**Pieces:** 1

**Pack dimensions:** 1000×90×100 mm

**Case weight:** 7.5 kg

## PALLET

**Pallet dimensions:** 120×120×100 cm

**Pieces per pallet:** 108

**Pallet total weight:** 810 kg

# MS 270

## ALUMINIUM BRACKET

### SLIDING BRACKETS

- ▶ Sliding
- Frontal hook
- Crossbar

### MENSOLE SCORREVOLI

- ▶ Scorrevole
- Aggancio frontale
- Barra a muro

### MATERIALS AND TREATMENT

**Material:** aluminium alloy

**Treatment:** epoxy resins in polyester on request

**Colour:** Natural/Ral 9002

**Joint:** high resistant screw M6×70 8.8

**Adjustment:** 2 adjustable gummy polypropilene feet

### DIMENSIONS AND LOADING CAPACITY

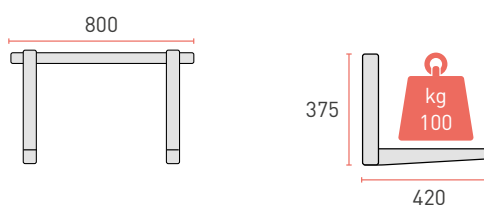

### LOAD CAPACITY

**Domestic use:** 100 kg

### BRACKET DRILLING DIAGRAM

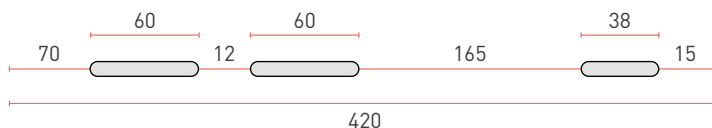

### BOX

**Pack:** carton box

**Pieces:** 1

**Pack dimensions:** 90×95×800 mm

**Case weight:** 2.15 kg

### PALLET

**Pallet dimensions:** 120×80×100 cm

**Pieces per pallet:** 117

**Pallet total weight:** 250 kg

Insulating washers



Levelling system



Wall fixing kit



Pre assembled



Certified quality



Rodigas®

AIPAA

DOLOMITICERT  
TESTING LABORATORY



TUV  
AUSTRIA

## OUR CERTIFICATIONS

Certified products and processes are the best quality assurance we can offer. It is for this reason that we continuously compare ourselves with accredited institutions and professionals who guide us on our journey.



Management System  
ISO 9001:2015  
[www.tuv.com](http://www.tuv.com)  
ID: 9105073334



Management System  
ISO 14001:2015  
[www.tuv.com](http://www.tuv.com)  
ID: 9105073334



Management System  
ISO 45001:2018  
[www.tuv.com](http://www.tuv.com)  
ID: 9105073334



SOCIUNI  
Licenza 0082 del 15/12/2015

# MS 220 - MS 222

## SLIDING BRACKETS

- Sliding
- ▶ Frontal hook
- Crossbar

## MENSOLE SCORREVOLI

- Scorrevole
- ▶ Aggancio frontale
- Barra a muro

## MATERIALS AND TREATMENT

**Materials:** electro-galvanised steel plate

**Treatment:** epoxy resins in polyester for outdoor

**Colour:** Ral 9002

**Joint:** high resistant screw M6×70 8.8

**Adjustment:** 2 adjustable gummy polypropilene feet (patented)

**Equipped with:** level to adjust the wall bar

## LOAD CAPACITY

**Domestic use:** 140 kg

**Load testing weight:** 420 kg

## BOX

**Pack:** carton box

**Pieces:** 1

## MS 220

**Pack dimensions:**

90×95×800 mm

**Case weight:** 4.84 kg

## MS 222

**Pack dimensions:**

90×95×1060 mm

**Case weight:** 5 kg

## PALLET

### MS 220

**Pallet dimensions:**

120×80×100 cm

**Pieces per pallet:**

117

**Pallet total weight:**

540 kg

### MS 222

**Pallet dimensions:**

106×106×100 cm

**Pieces per pallet:**

108

**Pallet total weight:**

600 kg



## DIMENSIONS AND LOADING CAPACITY

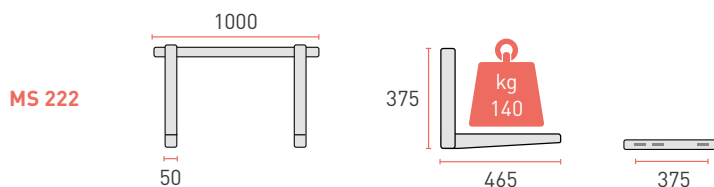
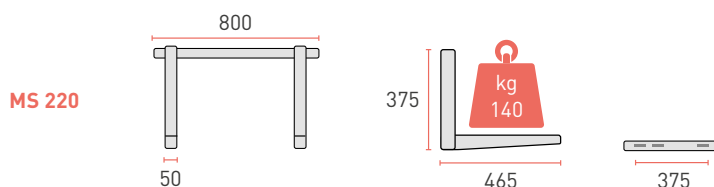

## BRACKET DRILLING DIAGRAM

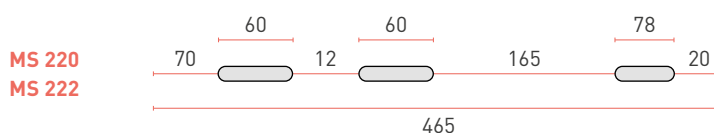

Adjustable rear foot



Wall fixing kit



Insulating washers



Levelling system



Certified quality





# MS 221 - MS 223

## SLIDING BRACKETS

- Sliding
- ▶ Frontal hook
- Crossbar

## MENSOLE SCORREVOLI

- Scorrevole
- ▶ Aggancio frontale
- Barra a muro

## MATERIALS AND TREATMENT

**Materials:** electro-galvanised steel plate

**Treatment:** epoxy resins in polyester for outdoor

**Colour:** Ral 9002

**Joint:** high resistant screw M6x70 8.8

**Adjustment:** 2 adjustable gummy polypropilene feet (patented)

**Equipped with:** level to adjust the wall bar

## DIMENSIONS AND LOADING CAPACITY

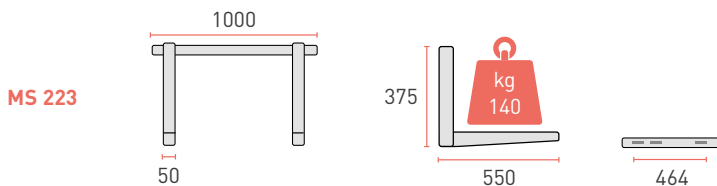
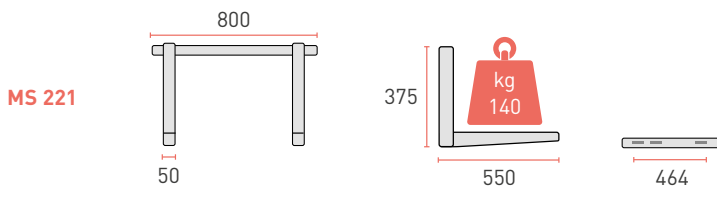

## LOAD CAPACITY

**Domestic use:** 140 kg

**Load testing weight:** 420 kg

## BRACKET DRILLING DIAGRAM

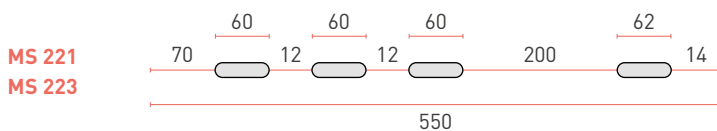

## BOX

**Pack:** carton box

**Pieces:** 1

## MS 221

**Pack dimensions:**

90x95x800 mm

**Case weight:** 4.84 kg

## MS 223

**Pack dimensions:**

90x95x1060 mm

**Case weight:** 5 kg

## PALLET

### MS 221

**Pallet dimensions:**

120x80x100 cm

**Pieces per pallet:**

117

**Pallet total weight:**

540 kg

### MS 223

**Pallet dimensions:**

106x106x100 cm

**Pieces per pallet:**

108

**Pallet total weight:**

600 kg



Adjustable rear foot



Wall fixing kit



Insulating washers



Levelling system



Certified quality

# MS 224

## SLIDING BRACKETS

- Sliding
- ▶ Frontal hook
- Crossbar

## MENSOLE SCORREVOLI

- Scorrevole
- ▶ Aggancio frontale
- Barra a muro

## MATERIALS AND TREATMENT

**Materials:** electro-galvanised steel plate

**Treatment:** epoxy resins in polyester for outdoor

**Colour:** Ral 9002

**Joint:** high resistant screw M6×70 8.8

**Adjustment:** 2 adjustable gummy polypropilene feet (patented)

## LOAD CAPACITY

**Domestic use:** 140 kg

**Load testing weight:** 420 kg

## BOX

**Pack:** carton box

**Pieces:** 1

**Pack dimensions:** 960×85×90 mm

**Case weight:** 4,84 kg

## PALLET

**Pallet dimensions:** 120×120×100 cm

**Pieces per pallet:** 120

**Pallet total weight:** 540 kg

INTERNATIONAL  
PATENT



## DIMENSIONS AND LOADING CAPACITY

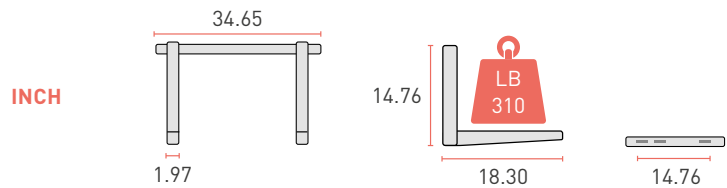
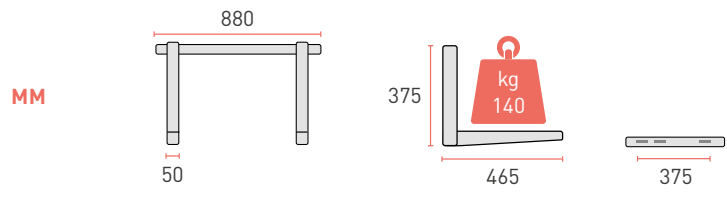

## BRACKET DRILLING DIAGRAM

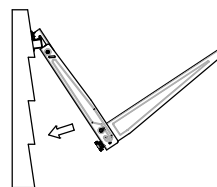
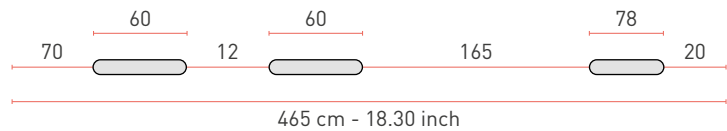

Screwless hooking

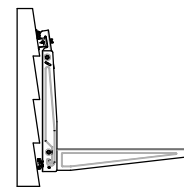

Wooden wall from 0° to 15°

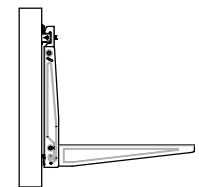

Brick wall



Certified quality

INTERNATIONAL  
PATENT



### DIMENSIONS AND LOADING CAPACITY

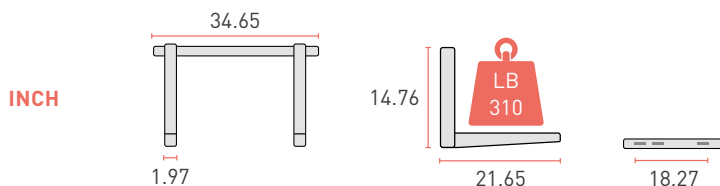
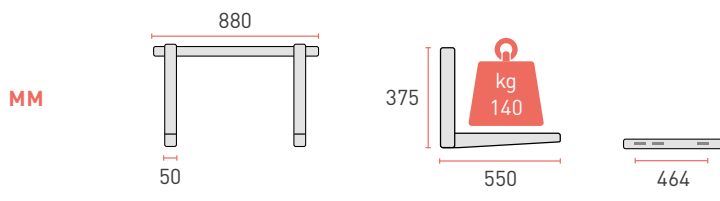

### BRACKET DRILLING DIAGRAM

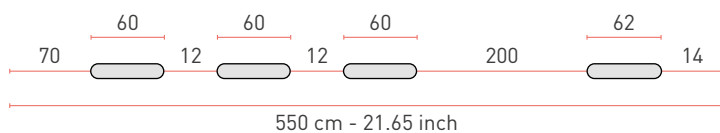

Adjustable  
rear foot



Wall  
fixing kit



Insulating  
washers



Levelling  
system



Regulating  
system



# MS 225

## SLIDING BRACKETS

- Sliding
- ▶ Frontal hook
- Crossbar

## MENSOLE SCORREVOLI

- Scorrevole
- ▶ Aggancio frontale
- Barra a muro

## MATERIALS AND TREATMENT

**Materials:** electro-galvanised steel plate

**Treatment:** epoxy resins in polyester for outdoor

**Colour:** Ral 9002

**Joint:** high resistant screw M6×70 8.8

**Adjustment:** 2 adjustable gummy polypropilene feet (patented)

## LOAD CAPACITY

**Domestic use:** 140 kg

**Load testing weight:** 420 kg



Certified quality

# MS 207 - MS 209

## SLIDING BRACKETS

- Sliding
- ▶ Frontal hook
- Crossbar

## MENSOLE SCORREVOLI

- Scorrevole
- ▶ Aggancio frontale
- Barra a muro



## MATERIALS AND TREATMENT

**Materials:** electro-galvanised steel plate

**Horizontal rod material:** aluminium alloy

**Treatment:** epoxy resins in polyester for outdoor

**Colour:** Ral 9002

**Adjustment:** 2 adjustable gummy polypropilene feet (patented)

## LOAD CAPACITY

**Domestic use:** 140 kg

**Load testing weight:** 420 kg

## BOX

**Pack:** carton box

**Pieces:** 1

**Pack dimensions:** 90×95×1060 mm

**Case weight:** 5 kg

## PALLET

**Pallet dimensions:** 120×80×100 cm

**Pieces per pallet:** 117

**Pallet total weight:** 600 kg

## DIMENSIONS AND LOADING CAPACITY

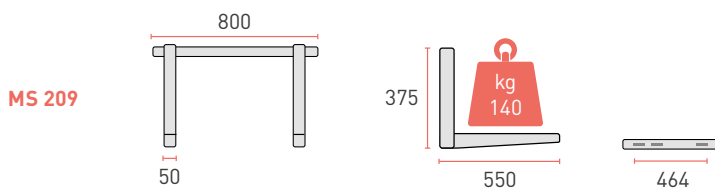
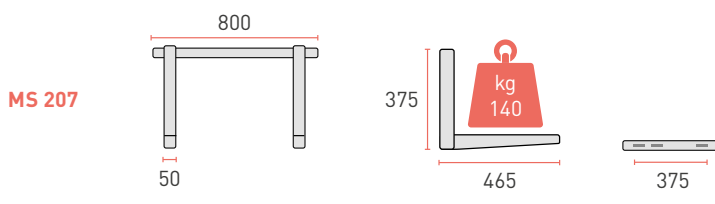

## BRACKET DRILLING DIAGRAM

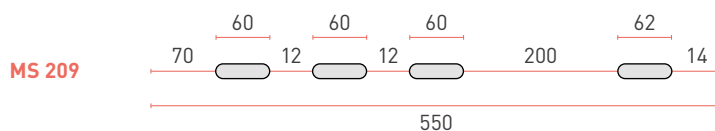
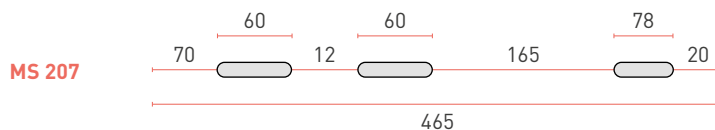

Adjustable rear foot



Wall fixing kit



Permanent marking



Levelling system



Certified quality





# MS 208 - MS 219

## SLIDING BRACKETS

- Sliding
- ▶ Frontal hook
- Crossbar

## MENSOLE SCORREVOLI

- Scorrevole
- ▶ Aggancio frontale
- Barra a muro

### DIMENSIONS AND LOADING CAPACITY

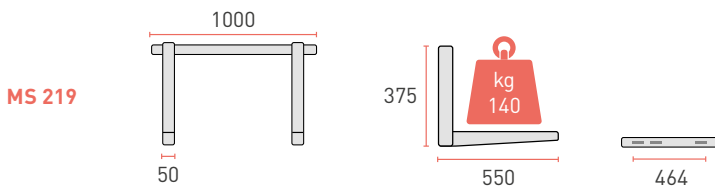
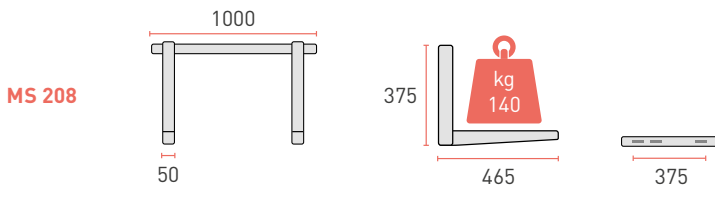

### BRACKET DRILLING DIAGRAM

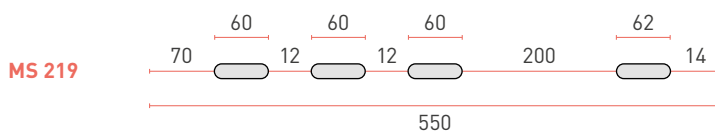
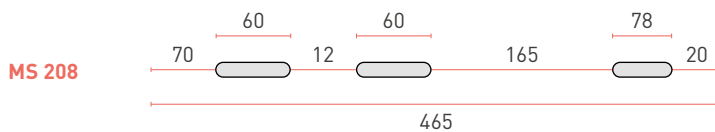

Adjustable rear foot



Wall fixing kit



Insulating washers



Levelling system

### MATERIALS AND TREATMENT

**Shelf material:** electro-galvanised steel plate

**Horizontal rod material:** aluminium alloy

**Treatment:** epoxy resins in polyester for outdoor

**Colour:** Ral 9002

**Joint:** high resistant screw M6×70 8.8

**Adjustment:** 2 adjustable gummy polypropilene feet (patented)

### LOAD CAPACITY

**Domestic use:** 140 kg

**Load testing weight:** 420 kg

### BOX

**Pack:** carton box

**Pieces:** 1

**Pack dimensions:** 90×95×1060 mm

**Case weight:** 5 kg

### PALLET

**Pallet dimensions:** 106×106×100 cm

**Pieces per pallet:** 108

**Pallet total weight:** 550 kg



Certified quality

# MS 201 - MS 202

## SLIDING BRACKETS

- Sliding
- ▶ Frontal hook
- Crossbar

## MENSOLE SCORREVOLI

- Scorrevole
- ▶ Aggancio frontale
- Barra a muro



## MATERIALS AND TREATMENT

**Materials:** electro-galvanised steel plate

**Treatment:** epoxy resins in polyester for outdoor

**Colour:** Ral 9002

**Joint:** high resistant screw M6x70 8.8

**Adjustment:** 2 adjustable gummy polypropilene feet (patented)

## LOAD CAPACITY

**Domestic use:** 200 kg

**Load testing weight:** 600 kg

## DIMENSIONS AND LOADING CAPACITY

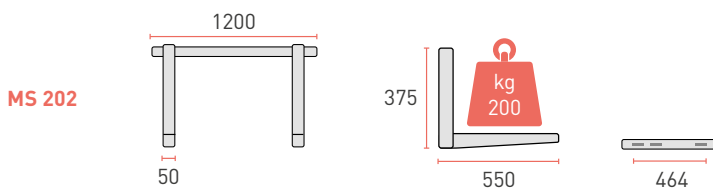
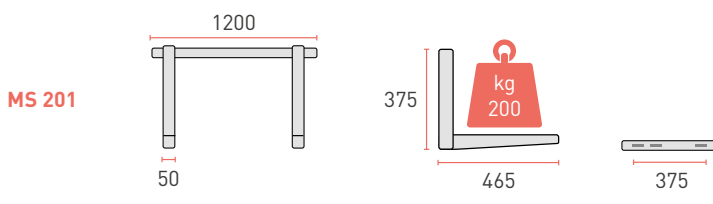

## BRACKET DRILLING DIAGRAM

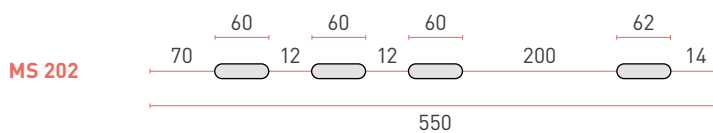
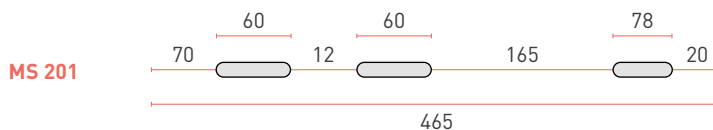

## BOX

**Pack:** carton box

**Pieces:** 1

**Pack dimensions:** 120x20x13 mm

## PALLET

**Pallet dimensions:** 120x120x140 cm

**Pieces per pallet:** 40



Adjustable rear foot



Wall fixing kit



Insulating washers



Levelling system



Certified quality



# MS 203

## SLIDING BRACKETS

- Sliding
- ▶ Frontal hook
- Crossbar

## MENSOLE SCORREVOLI

- Scorrevole
- ▶ Aggancio frontale
- Barra a muro

## MATERIALS AND TREATMENT

**Materials:** electro-galvanised steel plate

**Treatment:** epoxy resins in polyester for outdoor

**Colour:** Ral 9002

**Joint:** high resistant screw M6×70 8.8

**Adjustment:** 2 adjustable gummy polypropilene feet (patented)

## DIMENSIONS AND LOADING CAPACITY

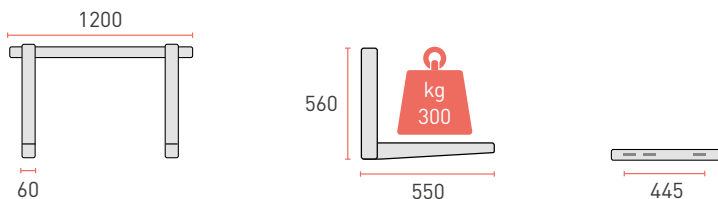

## BRACKET DRILLING DIAGRAM

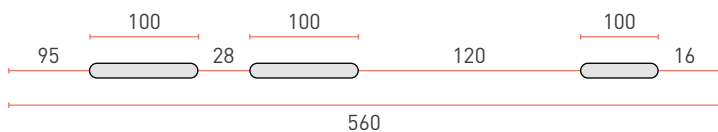

## LOAD CAPACITY

**Domestic use:** 300 kg

**Load testing weight:** 900 kg

## BOX

**Pack:** carton box

**Pieces:** 1

**Pack dimensions:** 120×20×13 mm

## PALLET

**Pallet dimensions:** 120×120×140 cm

**Pieces per pallet:** 40

Adjustable rear foot



Insulating washers



Wall fixing kit



Levelling system



Certified quality

# MS 205/B

# MS 205/B

## SLIDING BRACKETS

- Sliding
- Frontal hook
- ▶ Crossbar

## MENSOLE SCORREVOLI

- Scorrevole
- Aggancio frontale
- ▶ Barra a muro



## MATERIALS AND TREATMENT

**Shelf material:** electro-galvanised steel plate

**Horizontal rod material:** aluminium alloy

**Treatment:** epoxy resins in polyester for outdoor

**Colour:** Ral 9002

## LOAD CAPACITY

### MS 205/A

**Domestic use:** 140 kg

**Load testing weight:** 420 kg

### MS 205/B

**Domestic use:** 120 kg

**Load testing weight:** 360 kg

## DIMENSIONS AND LOADING CAPACITY

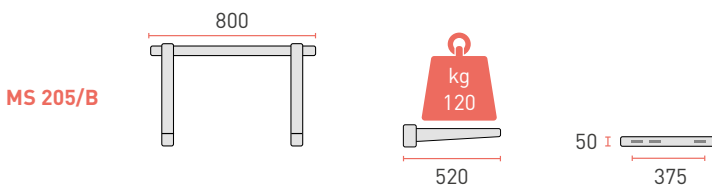
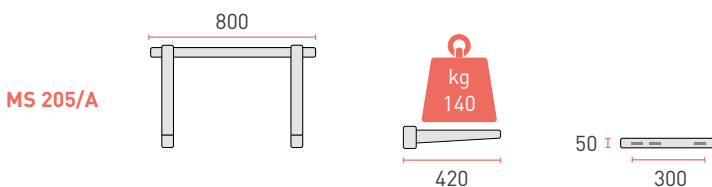

## BRACKET DRILLING DIAGRAM

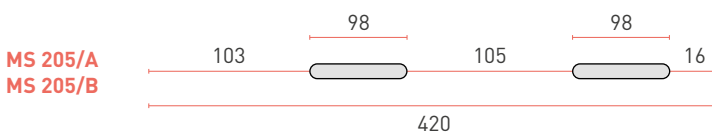

## BOX

**Pack:** carton box

**Pieces:** 1

**Pack dimensions:** 90×95×800 mm

**Case weight:** 3.5 kg

## PALLET

**Pallet dimensions:** 120×80×100 cm

**Pieces per pallet:** 117

**Pallet total weight:** 585 kg



Wall fixing kit



Insulating washers



Levelling system



Certified quality





# MS 206/A MS 206/B

## SLIDING BRACKETS

- Sliding
- Frontal hook
- ▶ Crossbar

## MENSOLE SCORREVOLI

- Scorrevole
- Aggancio frontale
- ▶ Barra a muro

### DIMENSIONS AND LOADING CAPACITY

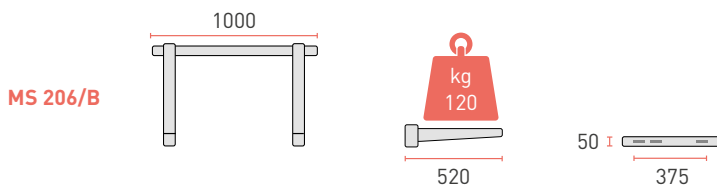
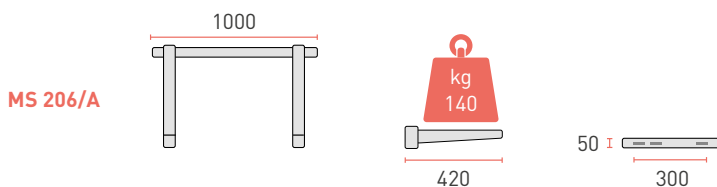

### BRACKET DRILLING DIAGRAM

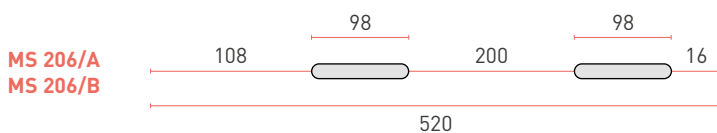

Wall fixing kit



Insulating washers



Levelling system

### MATERIALS AND TREATMENT

**Shelf material:** electro-galvanised steel plate

**Horizontal rod material:** aluminium alloy

**Treatment:** epoxy resins in polyester for outdoor

**Colour:** Ral 9002

### LOAD CAPACITY

#### MS 206/A

**Domestic use:** 140 kg

**Load testing weight:** 420 kg

#### MS 206/B

**Domestic use:** 120 kg

**Load testing weight:** 360 kg

### BOX

**Pack:** carton box

**Pieces:** 1

**Pack dimensions:** 90×95×1060 mm

**Case weight:** 3.5 kg

### PALLET

**Pallet dimensions:** 120×80×100 cm

**Pieces per pallet:** 117

**Pallet total weight:** 585 kg



Certified quality

FOLL

DESIGNED  
BY FOLL



# DING

FOLDING BRACKETS  
MENSOLE PIEGHEVOLI

Rodigas<sup>®</sup>  
SRL 

# MS 120

## FOLDING BRACKETS MENSOLE PIEGHEVOLI

### MATERIALS AND TREATMENT

**Materials:** electro-galvanised steel

**Treatment:** epoxy resins in polyester for outdoor

**Colour:** Ral 9002

**Joint:** high resistant screw M6×70 8.8



### LOAD CAPACITY

**Domestic use:** 140 kg

**Load testing weight:** 420 kg

### BOX

**Pack:** carton box

**Pieces:** 1

**Pack dimensions:** 90×95×610 mm

**Case weight:** 2.44 kg

### PALLET

**Pallet dimensions:** 120×80×100 cm

**Pieces per pallet:** 170

**Pallet total weight:** 415 kg

### DIMENSIONS AND LOADING CAPACITY

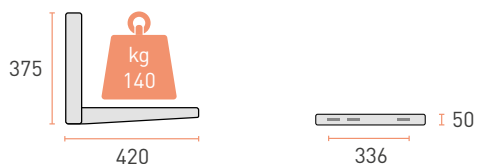

### BRACKET DRILLING DIAGRAM

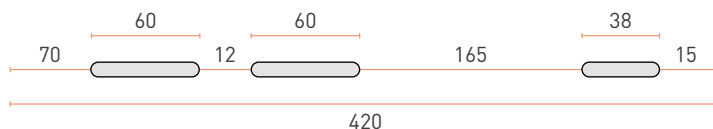

Wall  
fixing kit



Insulating  
washers



Permanent  
marking



Certified quality





# MS 117

## FOLDING BRACKETS MENSOLE PIEGHEVOLI

### MATERIALS AND TREATMENT

**Materials:** electro-galvanised steel

**Treatment:** epoxy resins in polyester for outdoor

**Colour:** Ral 9002

**Joint:** high resistant screw M6×70 8.8

### DIMENSIONS AND LOADING CAPACITY

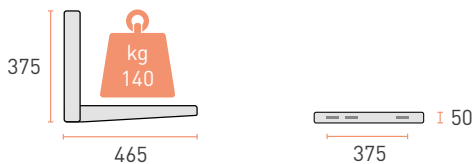

### LOAD CAPACITY

**Domestic use:** 140 kg

**Load testing weight:** 420 kg

### BRACKET DRILLING DIAGRAM

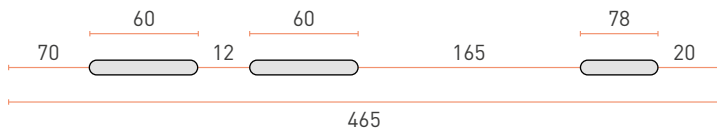

### BOX

**Pack:** carton box

**Pieces:** 1

**Pack dimensions:** 90×95×610 mm

**Case weight:** 2.44 kg

### PALLET

**Pallet dimensions:** 120×80×100 cm

**Pieces per pallet:** 170

**Pallet total weight:** 415 kg

Wall  
fixing kit



Insulating  
washers



Permanent  
marking



Pre  
assembled



Certified quality

# MS 118

## FOLDING BRACKETS MENSOLE PIEGHEVOLI

### MATERIALS AND TREATMENT

**Materials:** electro-galvanised steel

**Treatment:** epoxy resins in polyester for outdoor

**Colour:** Ral 9002

**Joint:** high resistant screw M6×70 8.8



### LOAD CAPACITY

**Domestic use:** 140 kg

**Load testing weight:** 420 kg

### BOX

**Pack:** carton box

**Pieces:** 1

**Pack dimensions:** 90×95×610 mm

**Case weight:** 3.8 kg

### PALLET

**Pallet dimensions:** 120×80×100 cm

**Pieces per pallet:** 170

**Pallet total weight:** 650 kg

### DIMENSIONS AND LOADING CAPACITY

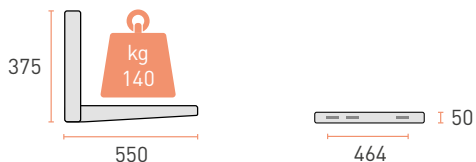

### BRACKET DRILLING DIAGRAM

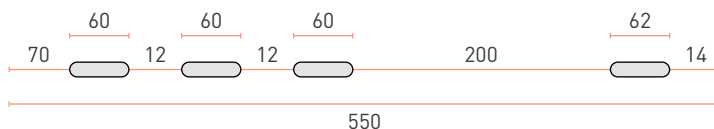

Wall  
fixing kit



Insulating  
washers



Permanent  
marking



Pre  
assembled



Certified quality



# MS 119

## FOLDING BRACKETS MENSOLE PIEGHEVOLI

### MATERIALS AND TREATMENT

**Materials:** electro-galvanised steel

**Treatment:** epoxy resins in polyester for outdoor

**Colour:** Ral 9002

**Joint:** high resistant screw M8×80 8.8

### DIMENSIONS AND LOADING CAPACITY

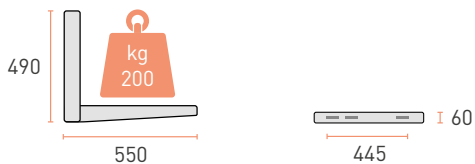

### LOAD CAPACITY

**Domestic use:** 200 kg

**Load testing weight:** 400 kg

### BRACKET DRILLING DIAGRAM

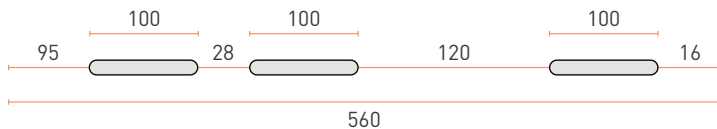

### BOX

**Pack:** carton box

**Pieces:** 1

**Pack dimensions:** 90×95×800 mm

**Case weight:** 5.8 kg

### PALLET

**Pallet dimensions:** 120×80×100 cm

**Pieces per pallet:** 117

**Pallet total weight:** 690 kg

Wall  
fixing kit



Insulating  
washers



Permanent  
marking



Pre  
assembled



Certified quality

# MS 139

## FOLDING BRACKETS MENSOLE PIEGHEVOLI

### MATERIALS AND TREATMENT

**Materials:** magnelis®

**Treatment:** epoxy resins in polyester for outdoor

**Colour:** Natural

**Joint:** high resistant screw M6×70 8.8

### LOAD CAPACITY

**Domestic use:** 100 kg

### BOX

**Pack:** carton box

**Pieces:** 1

**Pack dimensions:** 90×95×610 mm

**Case weight:** 2.44 kg

### PALLET

**Pallet dimensions:** 120×80×100 cm

**Pieces per pallet:** 170

**Pallet total weight:** 415 kg

### ABOUT MAGNELIS®

Our new line of technological product made in Magnelis® prevent corrosion more than standard product and is it recommended even in the most hostile environments.

Magnelis® is an exceptional metallic coating which provides a breakthrough in corrosion protection. For more info, please contact our technical team.

MAGNELIS®



### DIMENSIONS AND LOADING CAPACITY

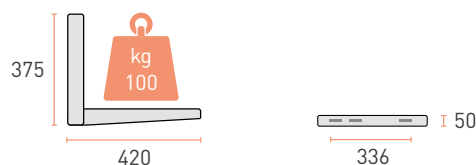

### BRACKET DRILLING DIAGRAM

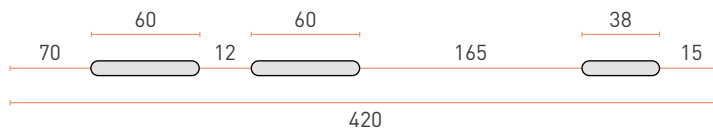

Wall  
fixing kit



Insulating  
washers



Permanent  
marking

### INFORMAZIONI TECNICHE

La nostra nuova linea di prodotti tecnologici realizzati in Magnelis® impedisce la corrosione più del prodotto standard e viene consigliata anche negli ambienti più corrosivi.

Magnelis® è un rivestimento metallico eccezionale che fornisce una penetrazione nella protezione contro la corrosione. Per ulteriori informazioni, contattare il team tecnico.



Certified quality



ALUMINIUM  
ALLOY



# MS 103

## FOLDING BRACKETS MENSOLE PIEGHEVOLI

### MATERIALS AND TREATMENT

- Materials:** aluminium alloy
- Treatment:** epoxy resins in polyester for outdoor
- Colour:** Ral 9002
- Joint:** high resistant screw M6×70 8.8

### DIMENSIONS AND LOADING CAPACITY

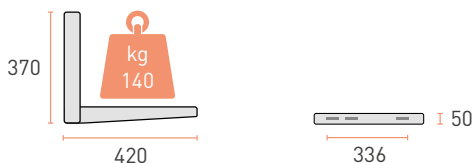

### LOAD CAPACITY

Standard use: 140 kg

### BRACKET DRILLING DIAGRAM

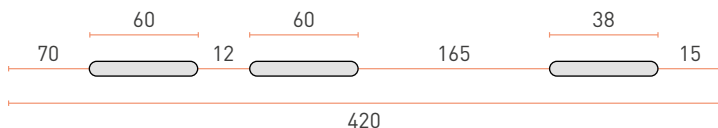

### BOX

- Pack:** carton box
- Pieces:** 1
- Pack dimensions:** 90×95×610 mm
- Case weight:** 1.7 kg

### PALLET

- Pallet dimensions:** 120×80×100 cm
- Pieces per pallet:** 117
- Pallet total weight:** 300 kg

Wall  
fixing kit



Insulating  
washers



Permanent  
marking



Pre  
assembled



Certified quality



WE

# WELDED

## WELDED BRACKETS

- Sliding
- Frontal hook
- Crossbar

## MENSOLE SALDATE

- Scorrevole
- Aggancio frontale
- Barra a muro

# MS 105 102

## WELDED BRACKETS

- ▶ Welded
  - Heavy load
  - Industrial
  - Extra load

## MENSOLE SALDATE

- ▶ Saldate
  - Pesante
  - Industriale
  - Extraportata



## MATERIALS AND TREATMENT

**Material:** pickled steel  
**Treatment:** hot galvanizing  
**Colour:** as treatment

## BOX

**MS 105 102**  
**Pack:** thermo retractable pack  
**Couples:** 20  
**Single piece weight:** 1.20 kg  
**Case weight:** 45 kg

## PALLET

**MS 105 102**  
**Pallet dimensions:** 120x80x100 cm  
**Couples per pallet:** 200  
**Pallet total weight:** 480 kg

## DIMENSIONS AND LOADING CAPACITY

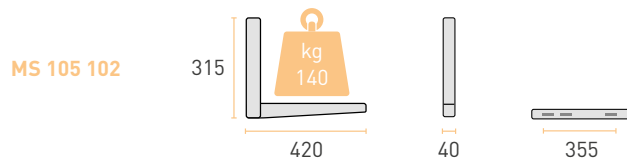

## BRACKET DRILLING DIAGRAM

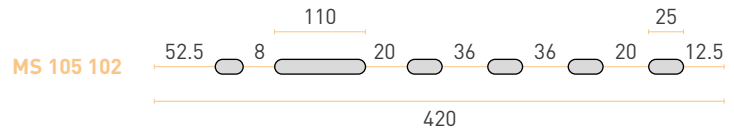

Certified quality





# MS 106 110 MS 116 107

## WELDED BRACKETS

- ▶ Welded
  - Heavy load
  - Industrial
  - Extra load

## MENSOLE SALDATE

- ▶ Saldate
  - Pesante
  - Industriale
  - Extraportata

## DIMENSIONS AND LOADING CAPACITY

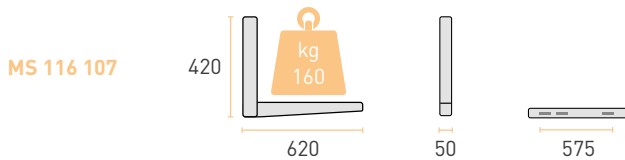
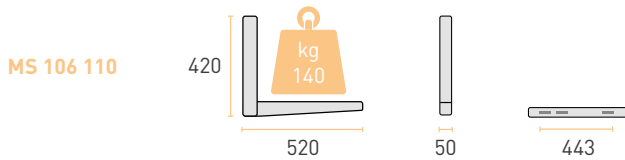

## BRACKET DRILLING DIAGRAM

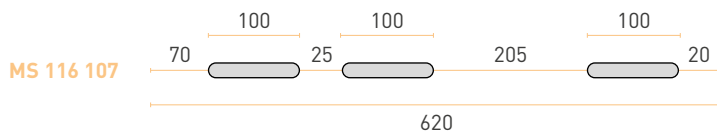
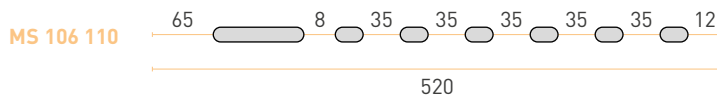

## MATERIALS AND TREATMENT

**Material:** pickled steel  
**Treatment:** hot galvanizing  
**Colour:** as treatment

## BOX

**MS 106 110**  
**Pack:** thermo retractable pack  
**Couples:** 12  
**Single piece weight:** 1.32 kg  
**Case weight:** 32 kg

**MS 116 107**  
**Pack:** thermo retractable pack  
**Couples:** 5  
**Single piece weight:** 2.60 kg  
**Case weight:** 26 kg

## PALLET

**MS 106 110**  
**Pallet dimensions:** 120×80×100 cm  
**Couples per pallet:** 168  
**Pallet total weight:** 350 kg

**MS 116 107**  
**Pallet dimensions:** 120×80×100 cm  
**Couples per pallet:** 90  
**Pallet total weight:** 450 kg



# MS 105

## WELDED BRACKETS

- ▶ Welded
  - Heavy load
  - Industrial
  - Extra load

## MENSOLE SALDATE

- ▶ Saldate
  - Pesante
  - Industriale
  - Extraportata



## MATERIALS AND TREATMENT

**Material:** pickled steel

**Treatment:** epoxy resins in polyester for outdoor

**Colour:** Ral 9002

## BOX

### MS 105

**Pack:** thermo retractable pack

**Couples:** 20

**Single piece weight:** 1.20 kg

**Case weight:** 45 kg

## PALLET

### MS 105

**Pallet dimensions:** 120x80x100 cm

**Couples per pallet:** 200

**Pallet total weight:** 480 kg

## DIMENSIONS AND LOADING CAPACITY

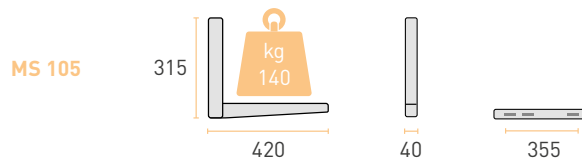

## BRACKET DRILLING DIAGRAM

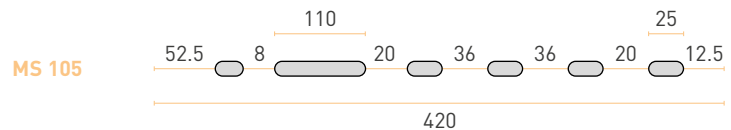

Certified quality

# MS 106 - MS 116



## WELDED BRACKETS

- ▶ Welded
  - Heavy load
  - Industrial
  - Extra load

## MENSOLE SALDATE

- ▶ Saldate
  - Pesante
  - Industriale
  - Extraportata

## MATERIALS AND TREATMENT

**Material:** pickled steel  
**Treatment:** hot galvanizing  
**Colour:** as treatment

## DIMENSIONS AND LOADING CAPACITY

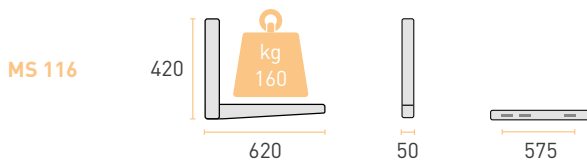
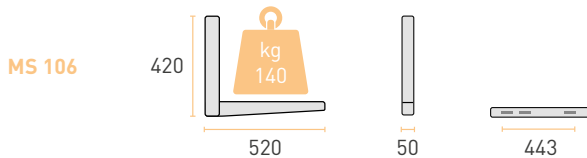

## BRACKET DRILLING DIAGRAM

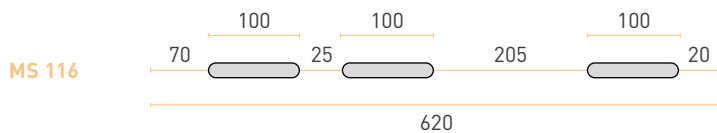
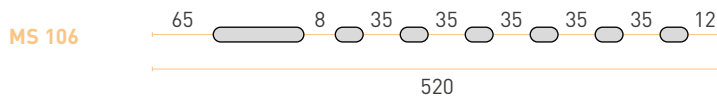

## BOX

**MS 106**  
**Pack:** thermo retractable pack  
**Couples:** 12  
**Single piece weight:** 1.32 kg  
**Case weight:** 32 kg

**MS 116**  
**Pack:** thermo retractable pack  
**Couples:** 5  
**Single piece weight:** 2.60 kg  
**Case weight:** 26 kg

## PALLET

**MS 106**  
**Pallet dimensions:** 120×80×100 cm  
**Couples per pallet:** 168  
**Pallet total weight:** 350 kg

**MS 116**  
**Pallet dimensions:** 120×80×100 cm  
**Couples per pallet:** 90  
**Pallet total weight:** 450 kg



Certified quality

# MS 105 302

## WELDED BRACKETS

- ▶ Welded
  - Heavy load
  - Industrial
  - Extra load

## MENSOLE SALDATE

- ▶ Saldate
  - Pesante
  - Industriale
  - Extraportata



## MATERIALS AND TREATMENT

**Material:** pickled steel

**Frist treatment:** electro galvanized

**Second treatment:** epoxy resins in polyester for outdoor

**Colour:** Ral 9002

## BOX

### MS 105 302

**Pack:** thermo retractable pack

**Couples:** 20

**Single piece weight:** 1.20 kg

**Case weight:** 45 kg

## PALLET

### MS 105 302

**Pallet dimensions:** 120×80×100 cm

**Couples per pallet:** 200

**Pallet total weight:** 480 kg

## DIMENSIONS AND LOADING CAPACITY

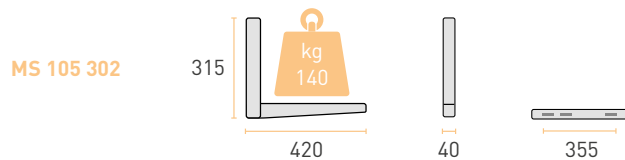

## BRACKET DRILLING DIAGRAM

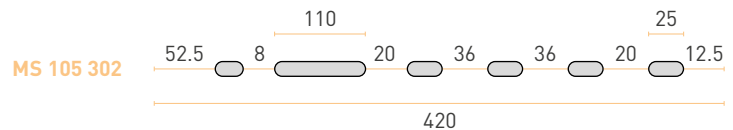



# MS 106 303 MS 116 304

## WELDED BRACKETS

- ▶ Welded
  - Heavy load
  - Industrial
  - Extra load

## MENSOLE SALDATE

- ▶ Saldate
  - Pesante
  - Industriale
  - Extraportata

## DIMENSIONS AND LOADING CAPACITY

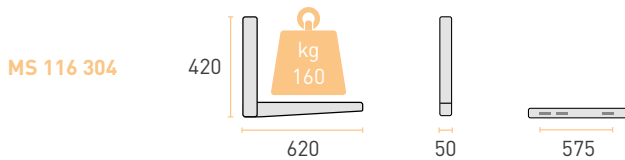
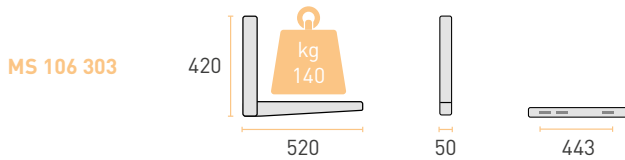

## BRACKET DRILLING DIAGRAM

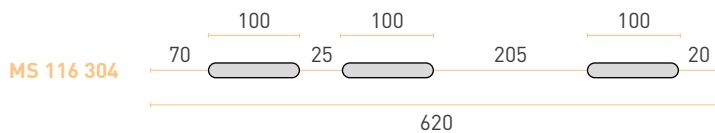
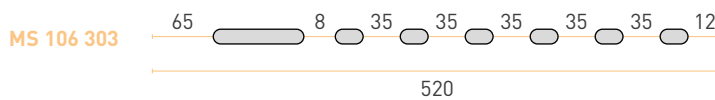

## MATERIALS AND TREATMENT

**Material:** pickled steel

**Frist treatment:** electro galvanized

**Second treatment:** epoxy resins in polyester for outdoor

**Colour:** Ral 9002

## BOX

### MS 106 303

**Pack:** thermo retractable pack

**Couples:** 12

**Single piece weight:** 1.32 kg

**Case weight:** 32 kg

### MS 116 304

**Pack:** thermo retractable pack

**Couples:** 5

**Single piece weight:** 2.60 kg

**Case weight:** 26 kg

## PALLET

### MS 106 303

**Pallet dimensions:** 120×80×100 cm

**Couples per pallet:** 168

**Pallet total weight:** 350 kg

### MS 116 304

**Pallet dimensions:** 120×80×100 cm

**Couples per pallet:** 90

**Pallet total weight:** 450 kg



Certified quality



# MS 401 - MS 402

## WELDED BRACKETS

- ▶ Welded
  - Heavy load
  - Industrial
  - Extra load

## MENSOLE SALDATE

- ▶ Saldate
  - Pesante
  - Industriale
  - Extraportata

## MATERIALS AND TREATMENT

**Material:** pickled steel

**Frist treatment:** electro galvanized

**Second treatment:** epoxy resins in polyester for outdoor

**Colour:** Ral 9002

## BOX

### MS 401

**Pack:** thermo-retractable pack

**Couples:** 5

**Case height:** 130 mm

**Single piece weight:** 2 kg

**Case weight:** 20 kg

### MS 402

**Pack:** thermo-retractable pack

**Couples:** 5

**Case height:** 130 mm

**Single piece weight:** 2.3 kg

**Case weight:** 23 kg

## PALLET

### MS 401

**Pallet dimensions:** 120×80×100 cm

**Couples per pallet:** 70

**Pallet total weight:** 300 kg

### MS 402

**Pallet dimensions:** 120×80×100 cm

**Couples per pallet:** 70

**Pallet total weight:** 350 kg



## DIMENSIONS AND LOADING CAPACITY

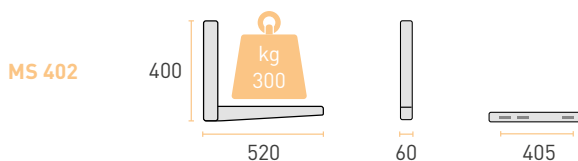
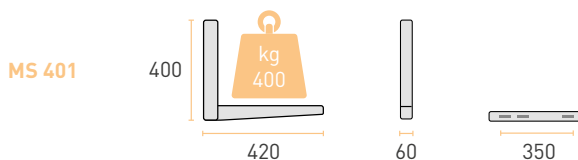

## BRACKET DRILLING DIAGRAM

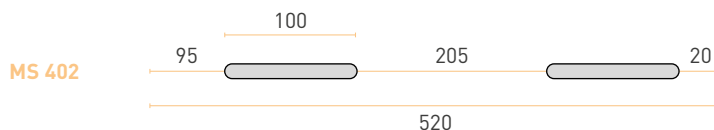
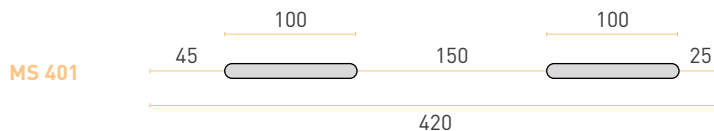



# MS 403

## WELDED BRACKETS

- ▶ Welded
- ▶ Heavy load
- ▶ Industrial
- ▶ Extra load

## MENSOLE SALDATE

- ▶ Saldate
- ▶ Pesante
- ▶ Industriale
- ▶ Extraportata

## MATERIALS AND TREATMENT

**Material:** pickled steel

**Frist treatment:** electro galvanized

**Second treatment:** epoxy resins in polyester for outdoor

**Colour:** Ral 9002

## DIMENSIONS AND LOADING CAPACITY

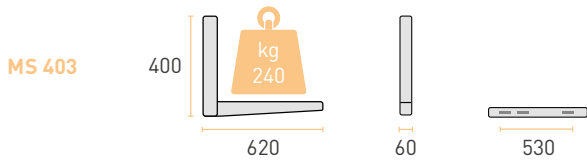

## BRACKET DRILLING DIAGRAM

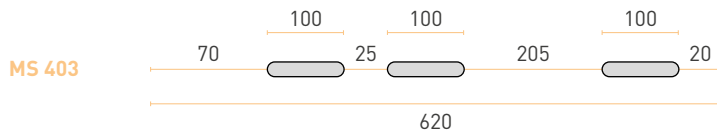

## BOX

### MS 403

**Pack:** thermo-retractable pack

**Couples:** 5

**Case height:** 130 mm

**Single piece weight:** 2 kg

**Case weight:** 20 kg

## PALLET

### MS 403

**Pallet dimensions:** 120×80×100 cm

**Couples per pallet:** 70

**Pallet total weight:** 300 kg



# MS 404 - MS 405

## WELDED BRACKETS

Welded

- ▶ Heavy load
- Industrial
- Extra load

## MENSOLE SALDATE

Saldate

- ▶ Pesante
- Industriale
- Extraportata

## MATERIALS AND TREATMENT

**Material:** pickled steel

**Frist treatment:** electro galvanized

**Second treatment:** epoxy resins in polyester for outdoor

**Colour:** Ral 9002

## BOX

### MS 404

**Pack:** thermo-retractable pack

**Couples:** 1

**Case height:** 65 mm

**Single piece weight:** 3 kg

**Case weight:** 6 kg

### MS 405

**Pack:** thermo-retractable pack

**Couples:** 1

**Case height:** 65 mm

**Single piece weight:** 4.5 kg

**Case weight:** 9 kg

## PALLET

### MS 404

**Pallet dimensions:** 120×80×100 cm

**Couples per pallet:** 30

**Pallet total weight:** 300 kg

### MS 405

**Pallet dimensions:** 120×80×100 cm

**Couples per pallet:** 13

**Pallet total weight:** 420 kg



## DIMENSIONS AND LOADING CAPACITY

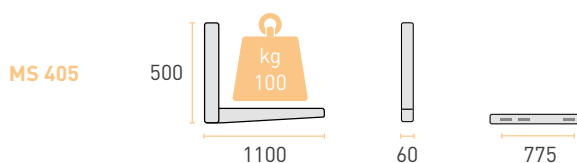
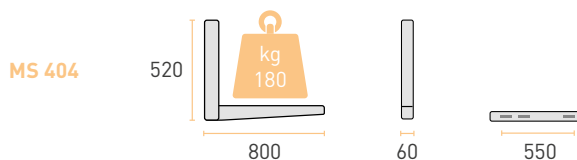

## BRACKET DRILLING DIAGRAM

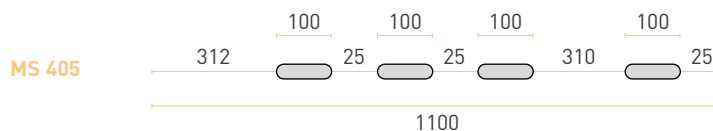
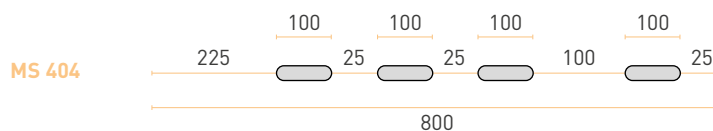

Certified quality



# MS 406

## WELDED BRACKETS

Welded

- ▶ Heavy load
- Industrial
- Extra load

## MENSOLE SALDATE

Saldate

- ▶ Pesante
- Industriale
- Extraportata

## MATERIALS AND TREATMENT

**Material:** pickled steel

**Frist treatment:** electro galvanized

**Second treatment:** epoxy resins in polyester for outdoor

**Colour:** Ral 9002

## DIMENSIONS AND LOADING CAPACITY

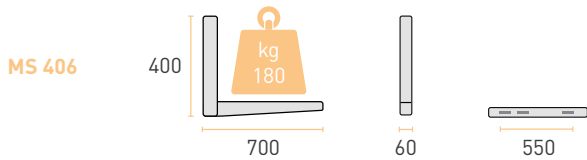

## BRACKET DRILLING DIAGRAM

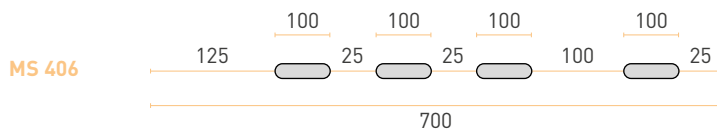

## BOX

### MS 406

**Pack:** thermo-retractable pack

**Couples:** 1

**Case height:** 65 mm

**Single piece weight:** 2.7 kg

**Case weight:** 5.4 kg

## PALLET

### MS 406

**Pallet dimensions:** 120×80×100 cm

**Couples per pallet:** 45

**Pallet total weight:** 420 kg



# MS 501 - MS 502

## WELDED BRACKETS

Welded

- ▶ Heavy load
- Industrial
- Extra load

## MENSOLE SALDATE

Saldate

- ▶ Pesante
- Industriale
- Extraportata

## MATERIALS AND TREATMENT

**Material:** pickled steel

**Frist treatment:** electro galvanized

**Second treatment:** epoxy resins in polyester for outdoor

**Colour:** Ral 9002

## BOX

### MS 501

**Pack:** thermo-retractable pack

**Couples:** 5

**Case height:** 170 mm

**Single piece weight:** 2.6 kg

**Case weight:** 26 kg

### MS 502

**Pack:** thermo-retractable pack

**Couples:** 5

**Case height:** 170 mm

**Single piece weight:** 3.1 kg

**Case weight:** 31 kg

## PALLET

### MS 501

**Pallet dimensions:** 120x80x100 cm

**Couples per pallet:** 60

**Pallet total weight:** 300 kg

### MS 502

**Pallet dimensions:** 120x80x100 cm

**Couples per pallet:** 60

**Pallet total weight:** 350 kg



## DIMENSIONS AND LOADING CAPACITY

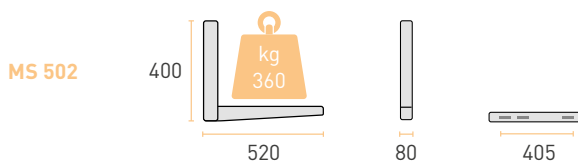
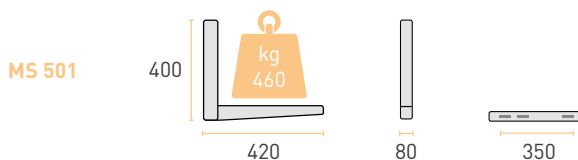

## BRACKET DRILLING DIAGRAM

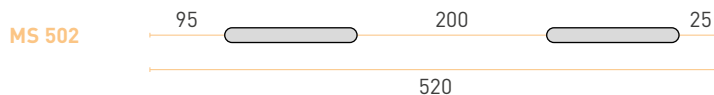
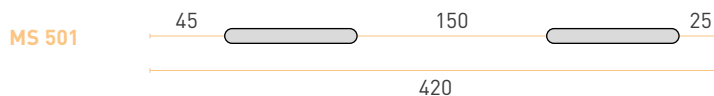

Certified quality





# MS 503 - MS 504

## WELDED BRACKETS

- Welded
- Heavy load
- ▶ Industrial
- Extra load

## MENSOLE SALDATE

- Saldate
- Pesante
- ▶ Industriale
- Extraportata

## MATERIALS AND TREATMENT

**Material:** pickled steel  
**Frist treatment:** electro galvanized  
**Second treatment:** epoxy resins in polyester for outdoor  
**Colour:** Ral 9002

## BOX

**MS 503**  
**Pack:** thermo-retractable pack  
**Couples:** 5  
**Case height:** 170 mm  
**Single piece weight:** 3.5 kg  
**Case weight:** 35 kg

**MS 504**  
**Pack:** thermo-retractable pack  
**Couples:** 1  
**Case height:** 80 mm  
**Single piece weight:** 3.9 kg  
**Case weight:** 8 kg

## PALLET

**MS 503**  
**Pallet dimensions:** 120×80×100 cm  
**Couples per pallet:** 60  
**Pallet total weight:** 400 kg

**MS 504**  
**Pallet dimensions:** 120×80×100 cm  
**Couples per pallet:** 24  
**Pallet total weight:** 200 kg

## DIMENSIONS AND LOADING CAPACITY

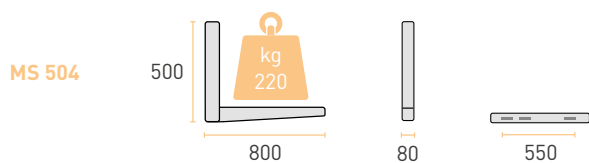
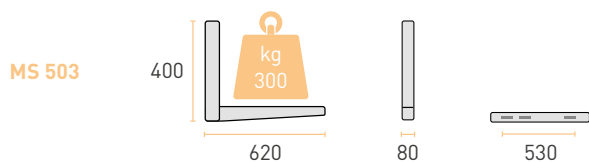

## BRACKET DRILLING DIAGRAM

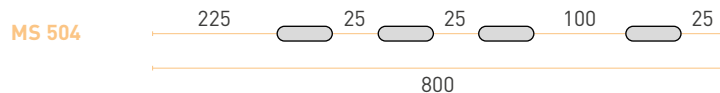
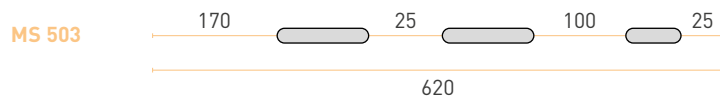

Certified quality

# MS 505

## WELDED BRACKETS

- Welded
- Heavy load
- ▶ Industrial
- Extra load

## MENSOLE SALDATE

- Saldate
- Pesante
- ▶ Industriale
- Extraportata

## MATERIALS AND TREATMENT

**Material:** pickled steel

**Frist treatment:** electro galvanized

**Second treatment:** epoxy resins in polyester for outdoor

**Colour:** Ral 9002

## BOX

### MS 505

**Pack:** thermo-retractable pack

**Couples:** 1

**Case height:** 80 mm

**Single piece weight:** 7 kg

**Case weight:** 14 kg

## PALLET

### MS 505

**Pallet dimensions:** 120×80×100 cm

**Couples per pallet:** 9



## DIMENSIONS AND LOADING CAPACITY

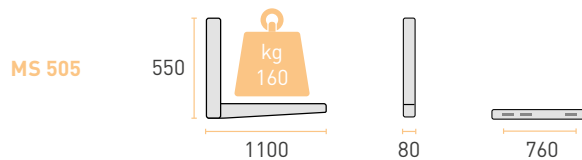

## BRACKET DRILLING DIAGRAM

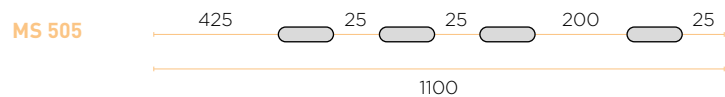

Certified quality



# MS 801 - MS 802 MS 803 - MS 804

## WELDED BRACKETS

- Welded
- Heavy load
- Industrial
- ▶ Extra load

## MENSOLE SALDATE

- Saldate
- Pesante
- Industriale
- ▶ Extraportata

### DIMENSIONS AND LOADING CAPACITY

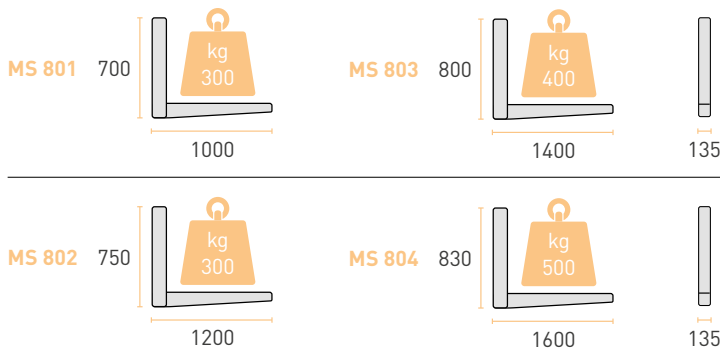

### BRACKET DRILLING DIAGRAM

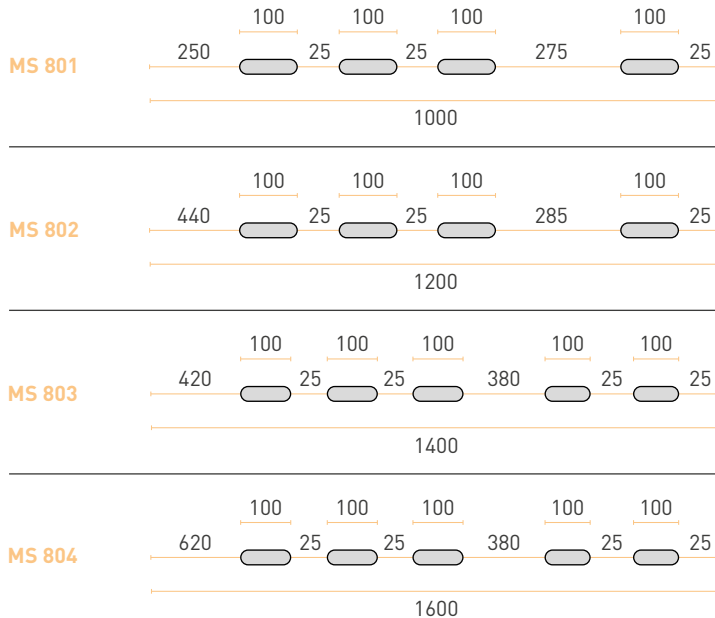

### MATERIALS AND TREATMENT

- Material:** pickled steel
- Frist treatment:** electro galvanized
- Second treatment:** epoxy resins in polyester for outdoor
- Colour:** Ral 9002

### BOX

- Pack:** thermo retractable pack
- Couples:** 1
- Case height:** 150 mm

### PALLET

- Pallet dimensions:** 120×80×100 cm



Industrial fixing



High resistance



Certified quality

# MS 111 - MS 112

## WELDED BRACKETS

- Welded
- Heavy load
- Industrial
- ▶ Extra load

## MENSOLE SALDATE

- Saldate
- Pesante
- Industriale
- ▶ Extraportata

## MATERIALS AND TREATMENT

**Material:** AISI 304 stainless steel plate

**Treatment:** epoxy resins in polyester on request

**Colour MS 111:** Natural

**Colour MS 112:** Ral 7035

## BOX

### MS 111

**Pack:** thermo-retractable pack

**Couples:** 10

**Single piece weight:** 1.9 kg

**Case weight:** 19 kg

### MS 112

**Pack:** thermo-retractable pack

**Couples:** 10

**Single piece weight:** 1.9 kg

**Case weight:** 19 kg

## PALLET

### MS 111

**Pallet dimensions:** 120×80×100 cm

**Couples per pallet:** 200

**Pallet total weight:** 480 kg

### MS 112

**Pallet dimensions:** 120×80×100 cm

**Couples per pallet:** 200

**Pallet total weight:** 480 kg

INOX



## DIMENSIONS AND LOADING CAPACITY

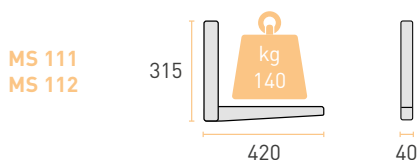

## BRACKET DRILLING DIAGRAM

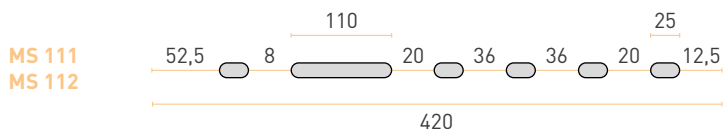

Certified quality

INOX



### DIMENSIONS AND LOADING CAPACITY

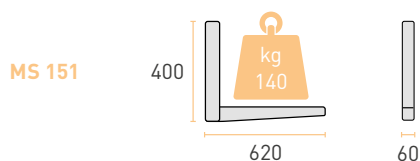
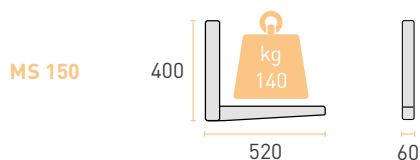

### BRACKET DRILLING DIAGRAM

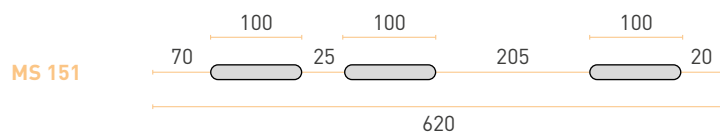
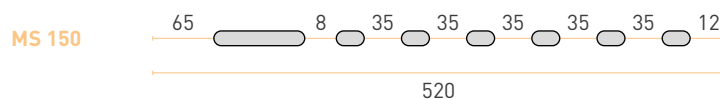

## MS 150 - MS 151

### WELDED BRACKETS

Welded  
Heavy load  
Industrial  
▶ Extra load

### MENSOLE SALDATE

Saldate  
Pesante  
Industriale  
▶ Extraportata

### MATERIALS AND TREATMENT

**Material:** AISI 304 stainless steel plate  
**Treatment:** epoxy resins in polyester on request  
**Colour:** Natural/Ral 7035

### BOX

**MS 150**  
**Pack:** thermo-retractable pack  
**Couples:** 5  
**Single piece weight:** 3.10 kg  
**Case weight:** 20 kg

**MS 151**  
**Pack:** thermo-retractable pack  
**Couples:** 5  
**Single piece weight:** 3.60 kg  
**Case weight:** 20 kg

### PALLET

**MS 150**  
**Pallet dimensions:** 120×80×100 cm  
**Couples per pallet:** 70  
**Pallet total weight:** 300 kg

**MS 151**  
**Pallet dimensions:** 120×80×100 cm  
**Couples per pallet:** 70  
**Pallet total weight:** 300 kg



# MV 105 - MV 106

## WELDED BRACKETS

- Welded
- Heavy load
- Industrial
- ▶ Extra load

## MENSOLE SALDATE

- Saldate
- Pesante
- Industriale
- ▶ Extraportata

## MATERIALS AND TREATMENT

**Material:** pickled steel  
**Treatment:** epoxy resins in polyester for outdoor  
**Colour:** Ral 9002

## LOAD CAPACITY

**Domestic use:** 140 kg  
**Load testing weight:** 420 kg

## BOX

### MV 105

**Pack:** thermo-retractable pack  
**Couples:** 20  
**Case height:** 200 mm  
**Single piece weight:** 1.12 kg  
**Case weight:** 45 kg

### MV 106

**Pack:** thermo-retractable pack  
**Couples:** 12  
**Case height:** 165 mm  
**Single piece weight:** 1.32 kg  
**Case weight:** 32 kg

## PALLET

### MV 105

**Pallet dimensions:** 120×80×100 cm  
**Couples per pallet:** 200  
**Pallet total weight:** 480 kg

### MV 106

**Pallet dimensions:** 120×80×100 cm  
**Couples per pallet:** 168  
**Pallet total weight:** 350 kg



## DIMENSIONS AND LOADING CAPACITY

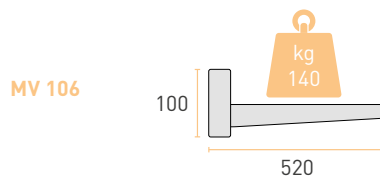
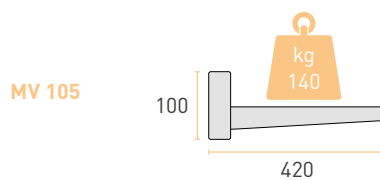

## BRACKET DRILLING DIAGRAM

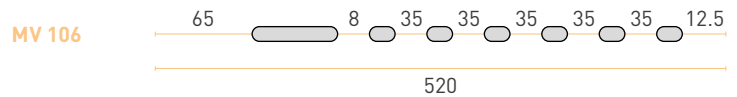
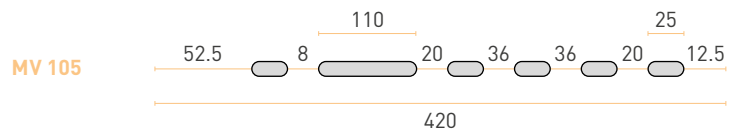

Permanent marking



Certified welds



Certified quality



### DIMENSIONS AND LOADING CAPACITY

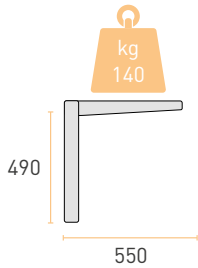

### BRACKET DRILLING DIAGRAM

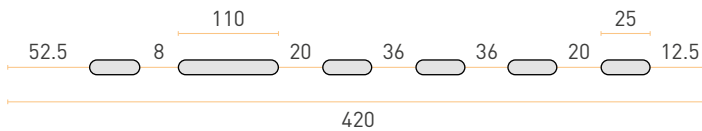

Permanent marking



Certified welds



## MR 105

### WELDED BRACKETS

- Welded
- Heavy load
- Industrial
- ▶ Extra load

### MENSOLE SALDATE

- Saldate
- Pesante
- Industriale
- ▶ Extraportata

### MATERIALS AND TREATMENT

**Materials:** pickled steel

**Treatment:** epoxy resins in polyester for outdoor

**Colour:** Ral 9002

### LOAD CAPACITY

**Domestic use:** 140 kg

**Load testing weight:** 420 kg

### BOX

**Pack:** thermo-retractable pack

**Couples:** 20

**Case height:** 200 mm

**Single piece weight:** 1.12 kg

**Case weight:** 45 kg

### PALLET

**Pallet dimensions:** 120×80×100 cm

**Pieces per pallet:** 200

**Pallet total weight:** 480 kg



R

# 00F

ROOF BRACKETS  
MENSOLE DA TETTO

Rodigas<sup>®</sup>  
SRL 

# MT 630 - MT 650

## ROOF BRACKETS MENSOLE DA TETTO

### MATERIALS AND TREATMENT

**Material:** electro-galvanised steel

**Treatment:** epoxy resins in polyester for outdoor

**Colour:** Ral 9002

**Inclination:** min 9° - max 45°



### LOAD CAPACITY

**Domestic use:** 140 kg

**Load testing weight:** 420 kg

### BOX

#### MT 630

**Pack:** carton box

**Pieces:** 1

**Pack dimensions:** 90×95×1060 mm

**Case weight:** 5.75 kg

#### MT 650

**Pack:** carton box

**Pieces:** 1

**Pack dimensions:** 90×95×1060 mm

**Case weight:** 6.45 kg

### PALLET

**Pallet dimensions:** 106×106×100 cm

**Pieces per pallet:** 108

**Pallet total weight:** 550 kg

### DIMENSIONS AND LOADING CAPACITY

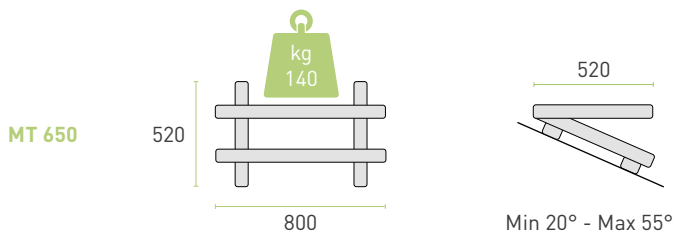
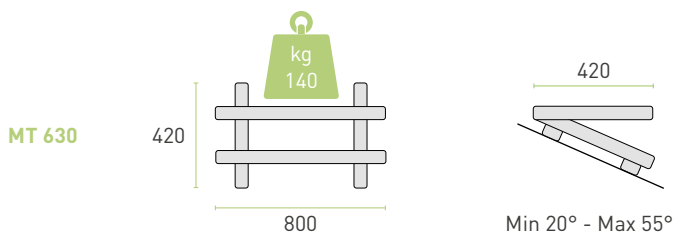

### BRACKET DRILLING DIAGRAM

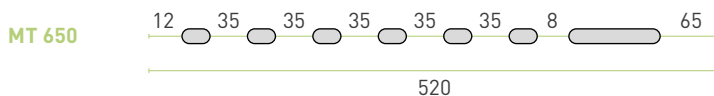
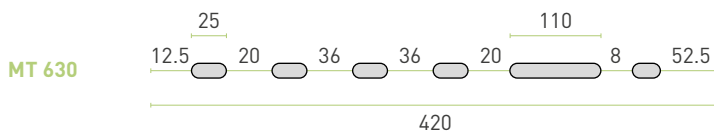

Certified quality



## MT 630 - MT 650 - ROOF BRACKETS

Roof bracket among the most used, it allows a rapid and accurate installation. It is supplied with air bubble level to simplify the installation and with polystyrene shims to facilitate the positioning on the roof tiles. In the assembly kit there are also the vibrations dampers to connect the air-conditioning unit and the kit of inox lamellae in order to fix the product to the roof.

## MT 630 - MT 650 - MENSOLE DA TETTO

Mensola da tetto tra le più utilizzate, permette una rapida e precisa installazione. Viene fornita completa di livella per semplificare l'installazione e spessori in polistirolo espanso per facilitare il posizionamento sui coppi e tegole. Nel kit di assemblaggio si trovano anche le rondelle isolanti per collegare il condizionatore e il kit di lamelle in inox per fissare il prodotto alla copertura.



FRONTAL FIXING



VIBRATIONS DAMPERS



HOLES TO REGULATE THE INCLINATION



INSULATING WASHERS



LEVELLING SYSTEM



FIXING KIT



Certified quality

# MT 600

## ROOF BRACKETS MENSOLE DA TETTO

### MATERIALS AND TREATMENT

**Material:** electro-galvanised steel

**Treatment:** epoxy resins in polyester for outdoor

**Colour:** Ral 9002

**Adjustable bars:** M12 stainless steel threaded stumps

**Bolts and nuts:** stainless steel



### LOAD CAPACITY

**Domestic use:** 140 kg

**Load testing weight:** 420 kg

### BOX

**Pack:** carton box

**Pieces:** 1

**Pack dimensions:** 90×95×1060 mm

**Case weight:** 6.28 kg

### PALLET

**Pallet dimensions:** 106×106×100 cm

**Pieces per pallet:** 108

**Pallet total weight:** 550 kg

### DIMENSIONS AND LOADING CAPACITY

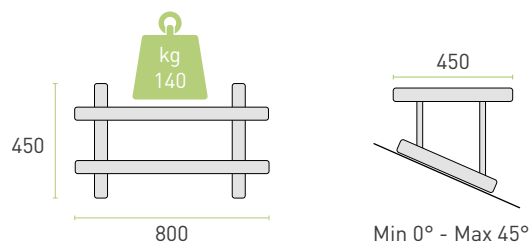

### BRACKET DRILLING DIAGRAM

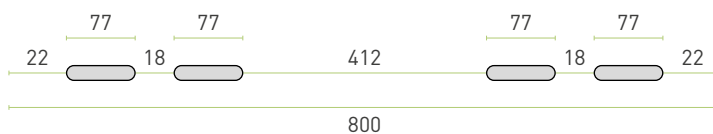

Insulating washers



Insulating washers



Levelling system



# MT 650

## ROOF BRACKETS MENSOLE DA TETTO

### MATERIALS AND TREATMENT

- Material:** electro-galvanised steel
- Treatment:** epoxy resins in polyester for outdoor
- Colour:** Ral 9002
- Adjustable bars:** M12 stainless steel threaded stumps
- Bolts and nuts:** stainless steel

### DIMENSIONS AND LOADING CAPACITY

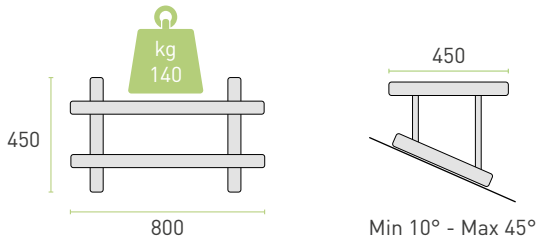

### LOAD CAPACITY

Domestic use: 140 kg

### BOX

- Pack:** carton box
- Pieces:** 1
- Pack dimensions:** 90×95×1060 mm
- Case weight:** 5.0 kg

### BRACKET DRILLING DIAGRAM

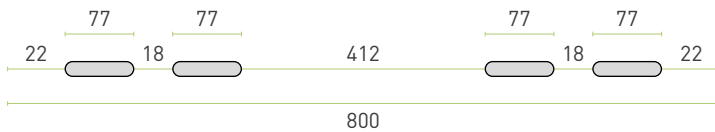

Insulating washers



Levelling system



### PALLET

- Pallet dimensions:** 106×106×100 cm
- Pieces per pallet:** 108
- Pallet total weight:** 550 kg



Certified quality



SP

# ECIAL

SPECIAL BRACKETS  
MENSOLE SPECIALI

Rodigas<sup>®</sup>  
SRL 



# MS 750

## SPECIAL BRACKETS MENSOLE SPECIALI

### MATERIALS AND TREATMENT

- Materials:** electro-galvanised steel plate
- Treatment:** painting epoxy resins in polyester
- Colour:** Ral 9002
- Adjustment:** high resistant screw M8x60 8.8
- Colour:** Ral 9002

### LOAD CAPACITY

Load Capacity: 200 kg



### DIMENSIONS AND LOADING CAPACITY

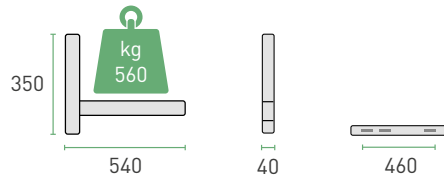

### BRACKET DRILLING DIAGRAM

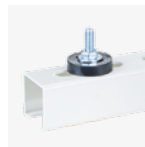
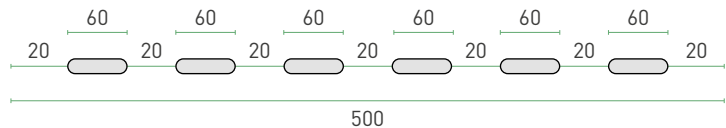

Insulating washers



Adjustable arm



Wall fixing kit



Certified quality

# MS 760 - MS 761

## SPECIAL BRACKETS MENSOLE SPECIALI



### MATERIALS AND TREATMENT

**Materials:** electro-galvanised steel plate

**Treatment:** painting epoxy resins in polyester

**Colour:** Ral 9002

**Joint:** high resistant screw M8x20 8.8

**Colour:** Ral 9002

### DIMENSIONS AND LOADING CAPACITY

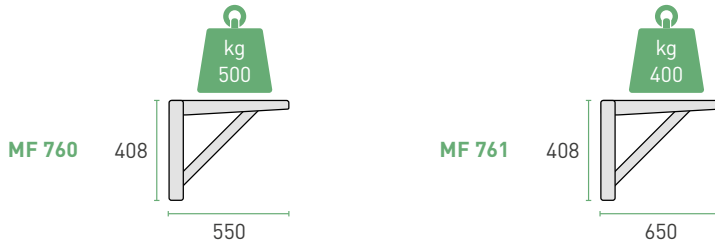

### LOAD CAPACITY

**MS 760 Load capacity:** 500 kg

**MS 761 Load capacity:** 400 kg

### BRACKET DRILLING DIAGRAM

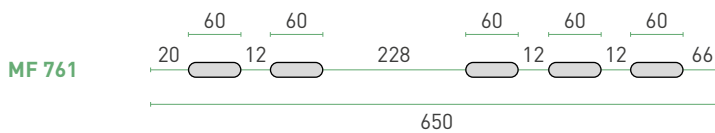
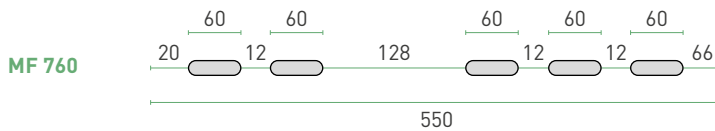

Structural profile



Assembleable bracket



AV 101 optional



Wall fixing kit



Certified quality

# MC 700

## SPECIAL BRACKETS MENSOLE SPECIALI

### MATERIALS AND TREATMENT

**Material:** electro-galvanised steel

**Treatment:** epoxy resins in polyester for outdoor

**Colour:** Ral 9002

### LOAD CAPACITY

**Domestic use:** 140 kg

**Load testing weight:** 420 kg

### BOX

**Pack:** nylon packaging

**Couples:** 1

**Pack dimensions:** 800×420×50 mm

**Working height:** 560 mm

**Case weight:** 8.2 kg



### DIMENSIONS AND LOADING CAPACITY

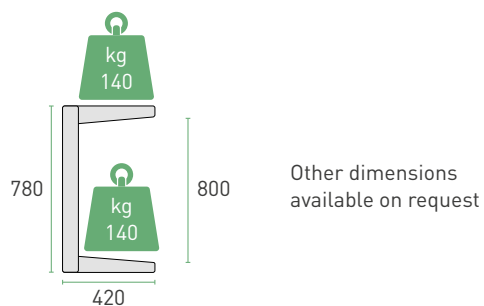

### BRACKET DRILLING DIAGRAM

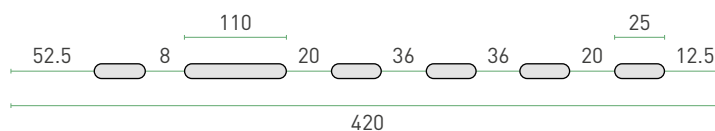

Permanent marking



Certified welds



Management System  
ISO 9001:2015  
ISO 14001:2015  
ISO 45001:2018  
www.rodigas.com  
pl 9106073334



Certified quality



# MC 720

## SPECIAL BRACKETS MENSOLE SPECIALI

### MATERIALS AND TREATMENT

**Material:** steel

**Treatment:** epoxy resins in polyester for outdoor

**Colour:** Ral 9002

### LOAD CAPACITY

**Domestic use:** 140 kg

**Load testing weight:** 420 kg

### BOX

**Pack:** nylon packaging

**Couples:** 1

**Pack dimensions:** 800×420×50 mm

### DIMENSIONS AND LOADING CAPACITY

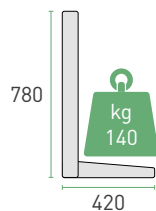

Other dimensions available on request

### BRACKET DRILLING DIAGRAM

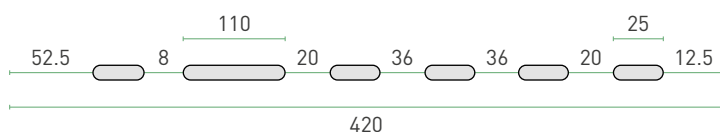

Permanent marking



Certified welds



Management System  
ISO 9001:2015  
ISO 14001:2015  
ISO 45001:2018  
www.rodigas.com  
p. 9106073334



Certified quality

# MS 105 SC1 MS 125 SC1 MS 106 SC1

## SPECIAL BRACKETS MENSOLE SPECIALI

### MATERIALS AND TREATMENT

**Material:** steel

**Treatment:** epoxy resins in polyester for outdoor

**Colour:** Ral 9002

### BOX

#### MS 105 SC1

**Couples:** 1

**Pack width:** 330 mm

**Pack length:** 460 mm

**Pack height:** 50 mm

#### MS 125 SC1

**Couples:** 1

**Pack width:** 430 mm

**Pack length:** 470 mm

**Pack height:** 55 mm

#### MS 106 SC1

**Couples:** 1

**Pack width:** 430 mm

**Pack length:** 580 mm

**Pack height:** 55 mm

### PALLET

#### MS 105 SC1

**Pallet dimensions:** 120×80×200 cm

**Pieces per pallet:** 200

#### MS 125 SC1

**Pallet dimensions:** 120×80×200 cm

**Pieces per pallet:** 152

#### MS 106 SC1

**Pallet dimensions:** 120×80×200 cm

**Pieces per pallet:** 128



### BRACKET DRILLING DIAGRAM

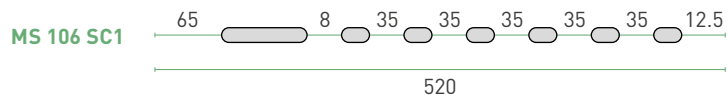
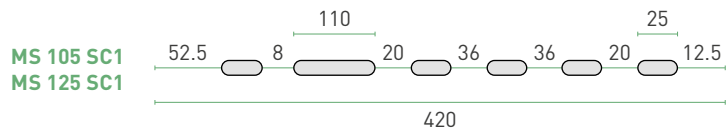

Certified quality



# MF 220 - MF 221



## SPECIAL BRACKETS MENSOLE SPECIALI

### MATERIALS AND TREATMENT

**Material:** electro-galvanised steel plate  
**Treatment:** epoxy resins in polyester for outdoor

**Colour:** Ral 9002

**Joint:** high resistant screw M6×70 8.8

**Adjustment:** 2 adjustable gummy polypropilene feet (patented)

### DIMENSIONS AND LOADING CAPACITY



### BOX

**Pack:** carton box

**Pieces:** 1

**Pack dimensions:** 970×85×90 mm

**Case weight:** 4.84 kg

### PALLET

**Pallet dimensions:** 106×106×100 cm

**Pieces per pallet:** 108 kg

**Pallet total weight:** 540 kg

### BRACKET DRILLING DIAGRAM

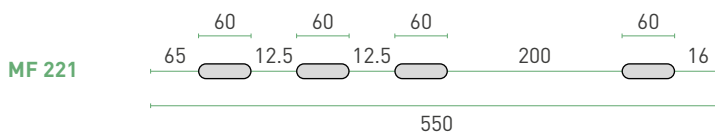
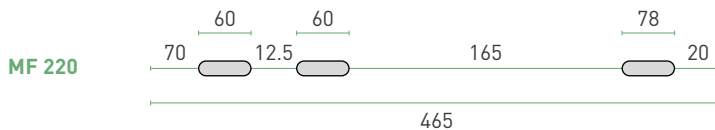

Wall fixing kit



Insulating washers



Levelling system



Certified quality

# MC 702

## SPECIAL BRACKETS MENSOLE SPECIALI

### MATERIALS AND TREATMENT

**Material:** steel

**Treatment:** epoxy resins in polyester for outdoor

**Colour:** Ral 9002

### LOAD CAPACITY

**Domestic use:** 140 kg

**Load testing weight:** 420 kg

### BOX

**Pack:** 1 couple

**Pack width:** 430 mm

**Pack length:** 580 mm

**Case height:** 55 mm

### PALLET

**Pallet dimensions:** 100×120×190 cm

**Pieces per pallet:** 128



### DIMENSIONS AND LOADING CAPACITY

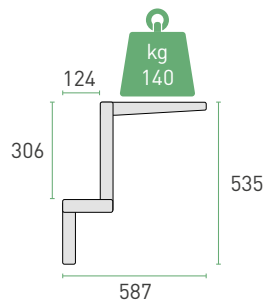

### BRACKET DRILLING DIAGRAM

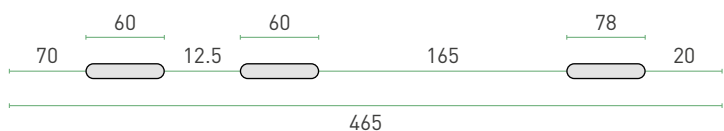

Wall  
fixing kit



Insulating  
washers





# MSP 915 MSP 916

## SPECIAL BRACKETS MENSOLE SPECIALI

### MATERIALS AND TREATMENT

**Vertical rod material:** extruded aluminium alloy

**Material:** electro-galvanised steel plate

**Treatment:** epoxy resins in polyester for outdoor

**Colour:** Ral 7021

**Joint:** high resistant screw M8x80 8.8

**Adjustment:** 4 adjustable gummy polypropilene feet (patented)

### DIMENSIONS AND LOADING CAPACITY

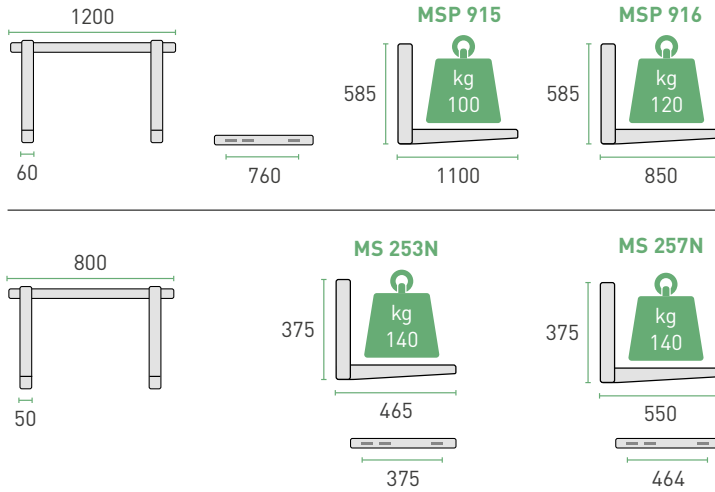

### LOAD CAPACITY

**MSP 915**

Standard use: 100 kg

**MSP 916**

Standard use: 120 kg

### BOX

Pack: carton box

Pieces: 1

### EXAMPLE OF INSTALLATION



### BRACKET DRILLING DIAGRAM

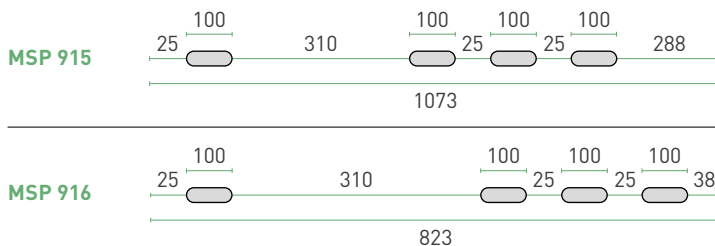

Certified quality

FL



# OOR

## FLOOR SUPPORTS

- PVC
- Single
- Steel
- Modular

## SUPPORTI PAVIMENTO

- PVC
- Singolo
- Lamiera
- Componibile

Rodigas<sup>®</sup>  
SRL 



# SP 350 - SP 450 SPE 350 - SPE 450 SP 1000

## FLOOR SUPPORTS

- ▶ PVC
  - Single
  - Steel
  - Modular

## SUPPORTI PAVIMENTO

- ▶ PVC
  - Singolo
  - Lamiera
  - Componibile



## MATERIALS AND TREATMENT

**Material:** Hard PVC self-extinguishing V0

### SP series equipped with:

- 4 fixing elements M 10
- 4 sticky vibroflex

### SPE series equipped with:

- 4 fixing elements M 10

## AVAILABLE ACCESSORIES

### TS

**Front cap height:** 100 mm

**Case:** 24 pieces

### TSE

**Front cap height:** 80 mm

**Case:** 24 pieces

## PALLET

**Pallet dimensions:** 120×80×100 cm

Fixing  
screw



## DIMENSIONS AND LOADING CAPACITY

### SP 350

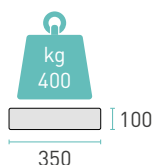

### SP 450

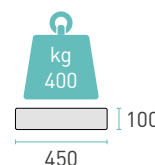

### SPE 350

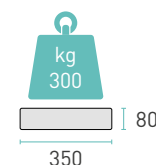

### SPE 450

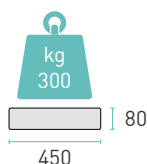

### SP 1000

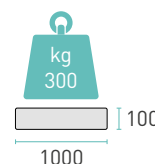

## BOX

CODE	CASE	PIECES	CASE DIMENSIONS	CASE WEIGHT
SP 350	Carton case	24	370×560×430	14.5 kg
SP 450	Carton case	24	470×560×430	18.5 kg
SPE 350	Carton case	24	360×450×350	10 kg
SPE 450	Carton case	24	460×460×350	13 kg
SP 1000	Carton case	4	1030×210×210	8 kg



# SP 510

## FLOOR SUPPORTS

- PVC
- ▶ Single
- Steel
- Modular

## SUPPORTI PAVIMENTO

- PVC
- ▶ Singolo
- Lamiera
- Componibile

## TECHNICAL CHARACTERISTICS

**Material:** PVC

**Equipped with:** antivibration and anti-slip system gummy ring

**Case:** 12 kit x 4 pcs

## LOAD CAPACITY

**Domestic use:** 400 kg

## DIMENSIONS AND LOADING CAPACITY

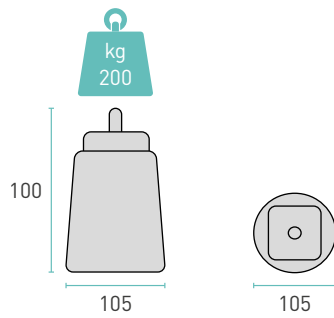

Anti vibration



No slip system

# SP 635 - SP 645

## FLOOR SUPPORTS

- PVC
- Single
- ▶ Steel
- Modular

## SUPPORTI PAVIMENTO

- PVC
- Singolo
- ▶ Lamiera
- Componibile

## MATERIALS AND TREATMENT

**Material:** galvanized steel

**Colour:** Ral 9002

**Equipped with:** vibration dampers and no slip washers

**Case:** 1 couple

## PALLET

**Pallet dimensions:** 120×80×100 cm

## BOX

CODE	CASE	PIECES
SP 635	Carton case	10
SP 645	Carton case	10



## DIMENSIONS AND LOADING CAPACITY

### SP 635

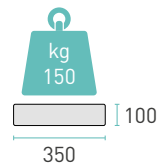

### SP 645

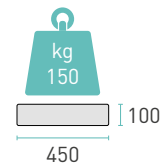

## BRACKET DRILLING DIAGRAM

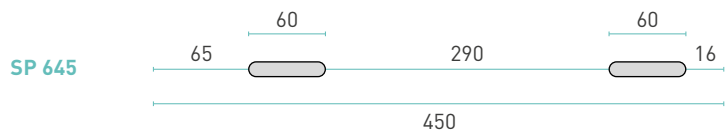
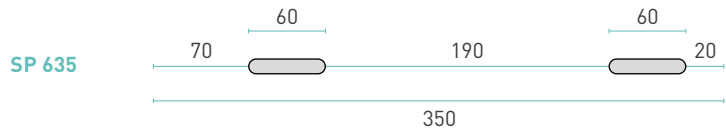

Optional insulating washers





# SP 750

## FLOOR SUPPORTS

- PVC
- Single
- Steel
- ▶ Modular

## SUPPORTI PAVIMENTO

- PVC
- Singolo
- Lamiera
- ▶ Componibile

## TECHNICAL CHARACTERISTICS

**Material:** galvanized steel

**Colour:** Ral 9002

**Equipped with:** vibration dampers and assembling screws

**Case:** 1 couple

**Extension:**  
Min L= 480 mm  
Max L= 830 mm

## LOAD CAPACITY

**Domestic use:** 200 kg

## DIMENSIONS AND LOADING CAPACITY

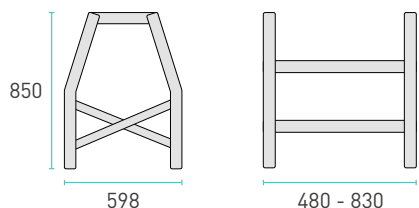

## BRACKET DRILLING DIAGRAM



Insulating washers



**AV 740**  
Optional feet dampers

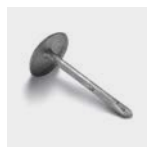

**SP 709**  
Optional rivet

# SP 700 - SP 740

# SP 701 - SP 741

## FLOOR SUPPORTS

- PVC
- Single
- Steel
- ▶ Modular

## SUPPORTI PAVIMENTO

- PVC
- Singolo
- Lamiera
- ▶ Componibile



## TECHNICAL CHARACTERISTICS

**Equipped with:** vibration dampers and assembling screws

**Case:** 1 couple

**Pieces per pallet:** 170

### Extension:

Min L= 480 mm  
Max L= 830 mm

### SP 700 - SP 740

**Material:** galvanized steel

**Colour:** Ral 9002

### SP 701 - SP 741

**Material:** stainless steel

**Colour:** Ral 7035

## LOAD CAPACITY

**Domestic use:** 200 kg

## DIMENSIONS AND LOADING CAPACITY

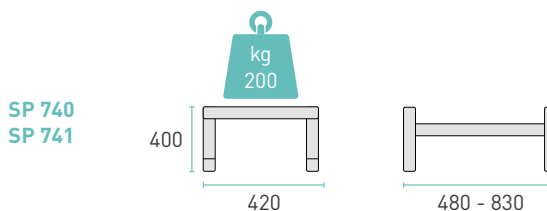
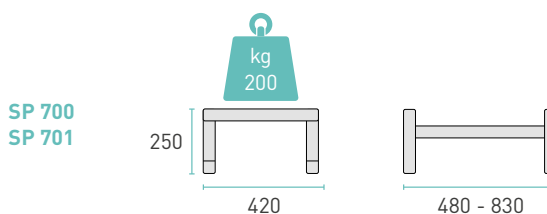

## BRACKET DRILLING DIAGRAM



Insulating washers



**AV 740**  
Optional feet dampers

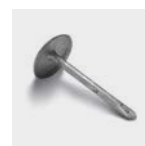

**SP 709**  
Optional rivet





# VS140 BUNDLE

## FLOOR SUPPORTS

- PVC
- Single
- Steel
- ▶ Modular

## SUPPORTI PAVIMENTO

- PVC
- Singolo
- Lamiera
- ▶ Componibile

## CONDENSATE DRIP TRAY

Draining pipe: diam. 20 mm

## MATERIALS AND TREATMENT

**Material:** electro-galvanised steel  
**Treatment:** epoxy resins in polyester for outdoor  
**Colour:** Ral 9002

## BOX

**Pack:** nylon packaging  
**Pieces:** 1 piece

## DIMENSIONS

VS 110

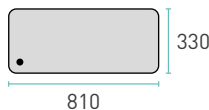

VS 210

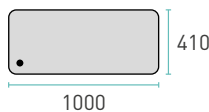

## CONDENSATE DRIP TRAY

VS140 use with VS110  
 VS240 use with VS210

## MATERIALS AND TREATMENT

**Material:** electro-galvanised steel  
**Treatment:** epoxy resins in polyester for outdoor  
**Colour:** Ral 9002

## BOX

**Pack:** carton box  
**Pieces:** 1 couple

## DIMENSIONS

VS 140

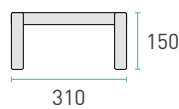

VS 240

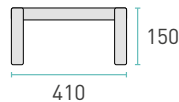

## GENERAL DATA

**Foot material:** SBR recycled rubber  
**Profile material:** aluminium  
**Profile dimension:** 21x22 mm  
**Fixing screw:** M10x30mm  
**Colour:** black

## DIMENSIONS AND LOADING CAPACITY

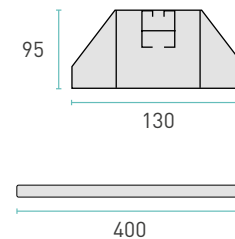

# SP 850 BLACK FLOOR SUPPORT

## FLOOR SUPPORTS

- PVC
- Single
- Steel
- Modular

## SUPPORTI PAVIMENTO

- PVC
- Singolo
- Lamiera
- Componibile

## TECHNICAL CHARACTERISTICS

**Material:** galvanized steel

**Colour:** Ral 7021

**Equipped with:** vibration dampers and assembling screws

**Case:** 1 couple

**Pieces per pallet:** 170

**Extension:**

Min L= 480 mm

Max L= 830 mm

## LOAD CAPACITY

**Domestic use:** 200 kg

## DIMENSIONS AND LOADING CAPACITY

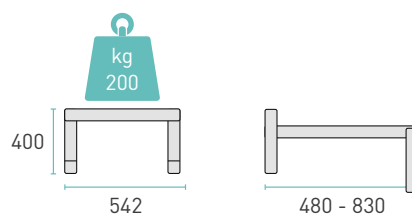

## BRACKET DRILLING DIAGRAM



Insulating washers



**AV 740**  
Optional feet dampers



**SP 709**  
Optional rivet



# DAM



# PER S

ANTIVIBRANTI  
VIBRATION DAMPERS

Rodigas<sup>®</sup>  
SRL 



# AV 101 - AV 301 AV 201 - AV 108 AV 302 - AV 202

## VIBRATION FEET DAMPERS ANTIVIBRANTI E PIEDINI

### PRODUCT DESCRIPTION

**Material:** rubber

**Hardness:** 50 shore

**Resistance to temperature:** -40° +60° C

### BOX

**Pack:** blister in nylon

**Pack width:** 4 anti-vibration pieces + bolts and nuts

**Multi-pack:** 50 kit

**Box dimension:** 40x20x20 cm

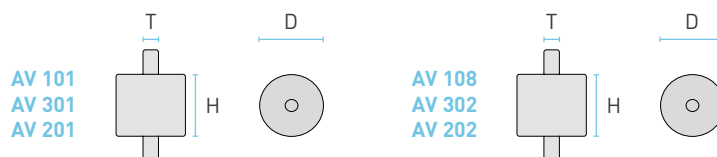

### VIBRATION DAMPERS KIT DATA

CODE	DIAMTER	HEIGHT	THREAD	COMPRESSION	CUT RESISTANCE
AV 101	30 mm	20 mm	2× M 8×20	80 daN	14 daN
AV 301	40 mm	30 mm	2× M 8×20	150 daN	25 daN
AV 201	40 mm	40 mm	2× M 8×20	120 daN	25 daN
AV 401	50 mm	40 mm	2× M 10×20	230 daN	35 daN

### VIBRATION FEET DAMPERS KIT DATA

CODE	DIAMTER	HEIGHT	THREAD	COMPRESSION	CUT RESISTANCE
AV 108	30 mm	20 mm	1× M 8×20	80 daN	14 daN
AV 302	40 mm	30 mm	1× M 8×20	150 daN	25 daN
AV 202	40 mm	40 mm	1× M 8×20	120 daN	25 daN
AV 402	50 mm	40 mm	1× M 10×20	230 daN	35 daN

### INOX VIBRATION FEET DAMPERS

CODE	DIAMTER	HEIGHT	THREAD	COMPRESSION	CUT RESISTANCE
AV 102	30 mm	20 mm	2× M 8×20	80 daN	14 daN

AV 410



AV 405



AV 410

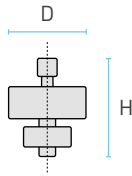

AV 405

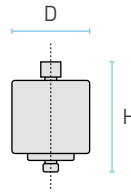

**VIBRATION DAMPERS KIT DATA**

CODE	DIAMTER 1	DIAMTER 2	HEIGHT	THREAD
AV 111	28 mm	40 mm	20 mm	2× M 8×20
AV 311	32 mm	40 mm	30 mm	2× M 8×20

**THROUGH SCREW KIT BASIC DATA**

CODE	DIAMTER	HEIGHT	THREAD
AV 410	40 mm	7 mm	M 8×40
AV 405	30 mm	25 mm	M 8×50

# AV 111 - AV 311 AV 410 - AV 405

**VIBRATION FEET DAMPERS  
ANTIVIBRANTI E PIEDINI**

**PRODUCT DESCRIPTION**

**Material:** rubber

**Hardness:** 50 shore

**Resistance to temperature:** -40° +60° C

**BOX**

**Pack:** blister in nylon

**Pack width:** 4 anti-vibration pieces + bolts and nuts

**Multi-pack:** 50 kit

**Box dimension:** 40×20×20 cm





CONDE

# NSATE

## CONDENSATE DRAINAGE SET

- Embedding Box
- Trays
- Universal Fitting
- Pipes
- Pump

## SCARICO CONDENSA

- Scatola
- Vaschette
- Raccordi
- Tubi
- Pompe

Rodigas<sup>®</sup>  
SRL



# PB 300

## CONDENSATE DRAINAGE SET

- ▶ Box
- Trays
- Universal Fitting
- Pipes
- Pump

## SCARICO CONDENSA

- ▶ Scatola
- Vaschette
- Raccordi
- Tubi
- Pompe

### PB 300 - EMBEDDING BOX IN PLASTIC

The embedding box is the first embedded box with “pouch” studied specifically for air conditioning employment. Thanks to the patented solutions, it is the only box that doesn't need cross girders as reinforcement to avoid any deformation; the cover is in fact equipped with very strong small plates used for fixing of the template of the conditioner. The material of this box allows to support any effort caused by the installation works and the pouch also excludes the necessity of substitution even in case of damage. The optional cover from outdoor CP300 is an unique body with the box and, for this reason, it makes unnecessary the application of an external systems of alignment (as required in other types of boxes); beside it protects the inside part of box during the building works. The box was introduced in the market on 1996, it had further implementations that allow a large diffusion and the constant success.

### PB 300 - EMBEDDING BOX IN PLASTIC

La prima scatola con marsupio studiata appositamente per il condizionamento. Grazie ai suoi brevetti, è l'unica scatola che non ha bisogno di traversini di rinforzo antideformazione, perchè il coperchio è dotato di placchette molto robuste da utilizzare nel fissaggio della dima del condizionatore. Il materiale di realizzazione è in grado di supportare qualsiasi sforzo dovuto alla messa in opera muraria ed il gocciolatoio esclude la necessità di sostituzione anche in caso di danneggiamento. Il coperchio da cantiere CP300 opzionale è un corpo unico con la scatola, che rende inutile l'applicazione di sistemi esterni di allineamento (di cui necessitano invece altri tipi di scatole) proteggendo anche l'interno scatola in fase di completamento delle opere murarie. Nel lungo utilizzo dal 1996, quando è stata immessa nel mercato, fino ad oggi, ha subito ulteriori implementazioni che ne determinano il continuo successo e larga diffusione.

## INTERNAL SPACE

Completely usable internal space thanks to the absence of stiffening bridges placed instead externally.

## SPAZIO INTERNO

Interno completamente sfruttabile grazie all'assenza di ponti per rinforzo posti esteriormente.



Multi pipe connection  
16/18/20 mm

Connessione per tubi  
diametro 16/18/20mm

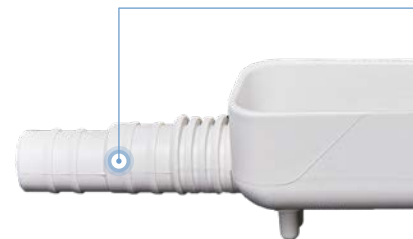

## MULTIFUNCTIONAL COVER

Construction site optional cover to protect the inside of the box during the wall plastering. Once protected the pipes by the cover during the wall plastering, separate the two ending parts to fix the indoor unit template.

## COPERCHIO DA CANTIERE

Questo robusto coperchio protegge l'interno della scatola e le tubazioni durante le fasi di intonacatura e finitura delle pareti. Separando le placchette alle estremità si riutilizzano in fase di installazione per il fissaggio della dima del condizionatore.



**LEVELLING SYSTEM**

Optional levelling system.

**SISTEMA DI LIVELLAMENTO**

Sistema di livellamento opzionale.

**DISCHARGE ON TWO SIDES**

Tub housed inside the box with inspectable hoses.

**SCARICO SU DUE LATI**

Vaschetta alloggiata all'interno della scatola con manicotti ispezionabili.

**SUITABLE PREDRILLED HOLES**

Predrilled holes positioned to allow the universal use.

**PREFORATURE IDONEE**

Predisposizione all'uscita della tubazioni lateralmente o posteriormente.

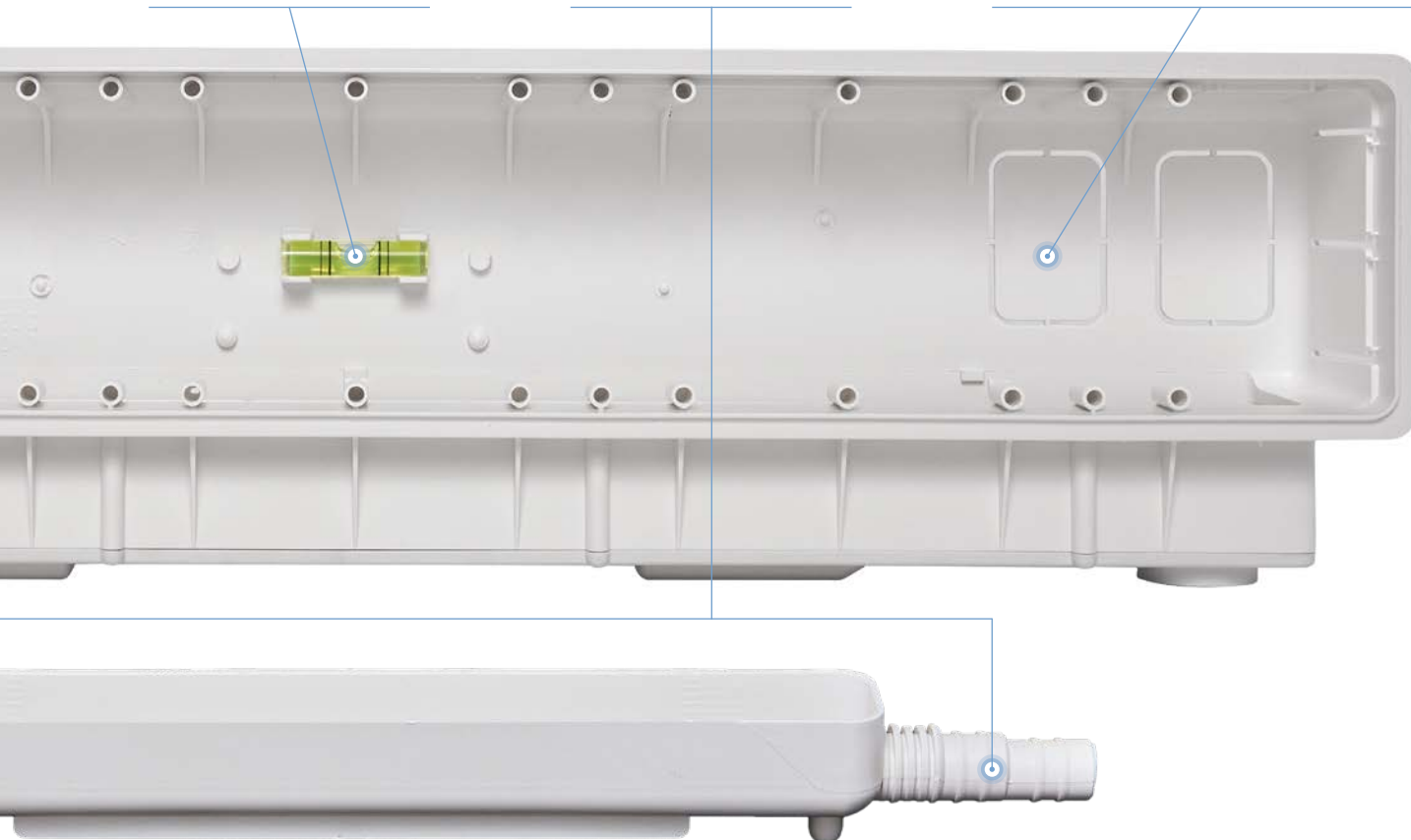
**OUTER LID**

Supplied with the box it is possible to use it before the installation of the internal unit.

**COPERCHIO ESTERNO**

Fornito con la scatola è possibile utilizzarlo prima dell'installazione dell'unità interna.

**FIXING PLATES**

It is possible to move them in different positions for fixing the installation plate.

**PLACCHE DI FISSAGGIO**

È possibile spostarle in posizioni diverse per fissare la piastra di installazione.

# PB 300

## CONDENSATE DRAINAGE SET

- ▶ Box
- Trays
- Universal Fitting
- Pipes
- Pump

## SCARICO CONDENSA

- ▶ Scatola
- Vaschette
- Raccordi
- Tubi
- Pompe



## MATERIALS AND TREATMENT

**Case length:** 540 mm

**Case height:** 130 mm

**Case width:** 65 mm

**Opening dimensions:** 525x80 mm

**Material supplied:** Finishing top cover

**Available accessories:** CP 300 Plastic yard cap, Box with 5 pcs

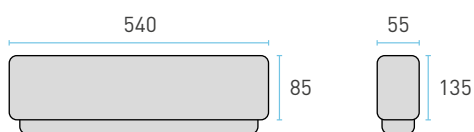

## BOX

**Pack:** carton box

**Pieces:** 15

**Case dimensions:** 570x360x430 mm

**Case weight:** 12.5 kg

## BOX WITH PS 106



## PALLET

**Pallet dimensions:** 120x80x220 cm

**Couples per pallet:** 300

**Pallet total weight:** 250 kg

## CP 300



Step 1



Step 2



## CP 300

### MULTIFUNCTIONAL COVER

Construction site optional cover to protect the inside of the box during the wall plastering. Once protected the pipes by the cover during the wall plastering, separate the two ending parts to fix the indoor unit template.

Coperchio da cantiere opzionale per proteggere l'interno della scatola durante l'intonacatura della parete. Una volta utilizzato il coperchio per proteggere le tubazioni in fase di intonacatura della parete si separano le due estremità e si utilizzano per il fissaggio della dima dell'unità interna.



### MATERIALS AND TREATMENT

**Material:** plastic  
**Colour:** white

### BOX

**Pack:** nylon packaging  
**Pieces:** 5 pcs

## CP 300 P

### FIXING PLATE

Plates applicable to the box for fixing the external air conditioning unit.

Placchette applicabili alla scatola per il fissaggio della dima dell'unità esterna di condizionamento.



### MATERIALS AND TREATMENT

**Material:** plastic  
**Colour:** white

### BOX

**Pack:** nylon packaging  
**Pieces:** 30 pcs

## CP 300 L

### LEVELING SYSTEM

Leveling system to be applied inside the box for a quick installation.

Sistema di livellamento da applicare all'interno della scatola per una corretta installazione di intonacatura della parete si separano le due estremità e si utilizzano per il fissaggio della dima dell'unità interna.



### MATERIALS AND TREATMENT

**Material:** plastic  
**Colour:** yellow fluid

### BOX

**Pack:** nylon packaging  
**Pieces:** 1 pc

# PB 400

## CONDENSATE DRAINAGE SET

- ▶ Box
- Trays
- Universal Fitting
- Pipes
- Pump

## SCARICO CONDENSA

- ▶ Scatola
- Vaschette
- Raccordi
- Tubi
- Pompe

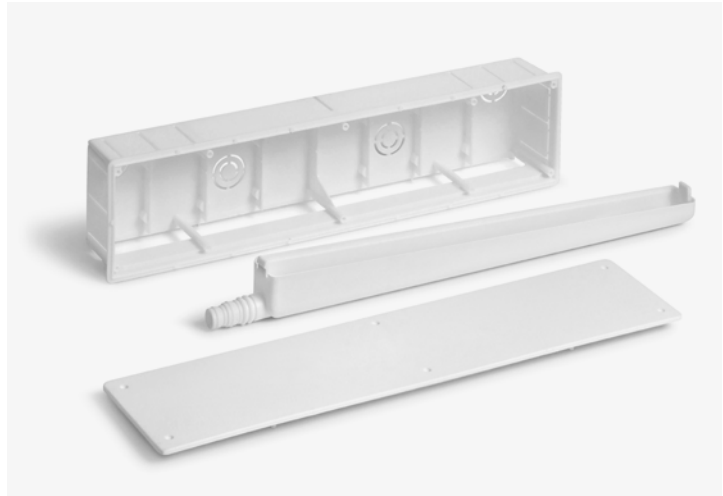

## MATERIALS AND TREATMENT

**Case length:** 430 mm

**Case height:** 95 mm

**Case width:** 65 mm

**Material supplied:** Finishing top cover

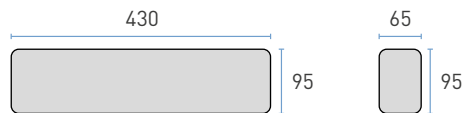

## BOX

**Pack:** carton box

**Pieces:** 20

**Case dimensions:**

## PB 400 - EMBEDDING BOX IN PLASTIC

Single packed into carton box. On packaging there is one carton cover protection to be used during wall construction. Package contents: plastic box, condensation tank and finiture cover.

## PALLET

**Pallet dimensions:** 120×80×220 cm

**Pieces per pallet:** 400

**Pallet total weight:** 250 kg

## PB 400 - SCATOLA DI PREDISPOSIZIONE

Fornita in imballo singolo con scatola di cartone. Sull'imballo è presente una protezione per le fasi di intonaco della parete. Contenuto della confezione: scatola, convogliatore di condensa e coperchio di finitura.

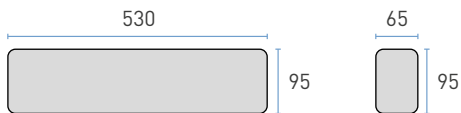
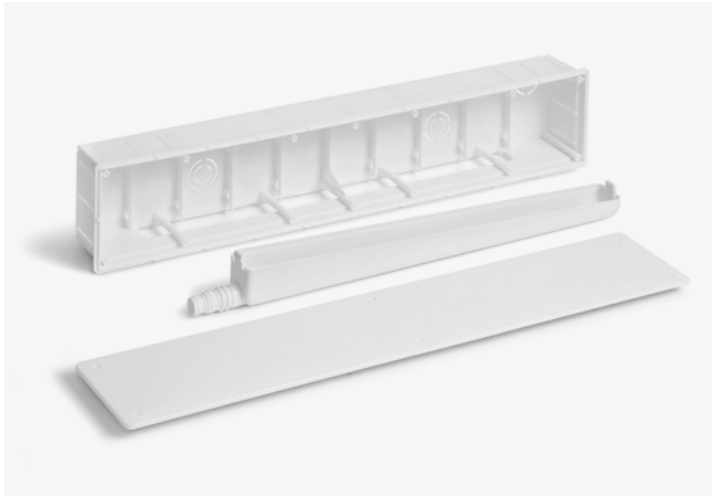

#### PB 500 - EMBEDDING BOX IN PLASTIC

Single packed into carton box. On packaging there is one carton cover protection to be used during wall construction. Package contents: plastic box, condensation tank and finiture cover.

#### PB 500 - SCATOLA DI PREDISPOSIZIONE

Fornita in imballo singolo con scatola di cartone. Sull'imballo è presente una protezione per le fasi di intonaco della parete. Contenuto della confezione: scatola, convogliatore di condensa e coperchio di finitura.

## PB 500

#### CONDENSATE DRAINAGE SET

- ▶ Box
- Trays
- Universal Fitting
- Pipes
- Pump

#### SCARICO CONDENSA

- ▶ Scatola
- Vaschette
- Raccordi
- Tubi
- Pompe

#### MATERIALS AND TREATMENT

**Case length:** 530 mm

**Case height:** 95 mm

**Case width:** 65 mm

**Material supplied:** Finishing top cover

#### BOX

**Pack:** carton box

**Pieces:** 20

**Case dimensions:**

#### PALLET

**Pallet dimensions:** 120×80×220 cm

**Pieces per pallet:** 400

**Pallet total weight:** 250 kg

# VS 110N VS 210N

## CONDENSATE DRIP TRAY BLACK

Draining pipe: diam. 20 mm

## MATERIALS AND TREATMENT

**Material:** electro-galvanised steel

**Treatment:** epoxy resins in polyester for outdoor

**Colour:** Ral 7016 matt

## BOX

**Pack:** nylon packaging

**Pieces:** 1 piece

## DIMENSIONS

VS 110

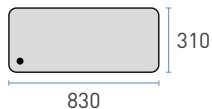

VS 210

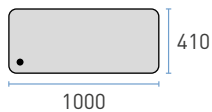

# VS 120N VS 220N

## CONDENSATE DRIP TRAY BLACK

VS120 use with VS110

VS220 use with VS210

Fixing screw included

## MATERIALS AND TREATMENT

**Material:** electro-galvanised steel

**Treatment:** epoxy resins in polyester for outdoor

**Colour:** Ral7016 matt

## BOX

**Pack:** nylon packaging

**Pieces:** 1 couple

## DIMENSIONS

VS 120

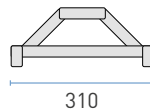

VS 220

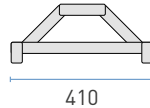



## OUR CERTIFICATIONS

---

Certified products and processes are the best quality assurance we can offer. It is for this reason that we continuously compare ourselves with accredited institutions and professionals who guide us on our journey.



Rodigas®  
BREL

AIPAA

DOLOMITI CERT  
TESTING LABORATORY



TUV  
AUSTRIA



Management System  
ISO 9001:2015

www.tuv.com  
ID: 8105073334



Management System  
ISO 14001:2015

www.tuv.com  
ID: 8105073334



Management System  
ISO 45001:2018

www.tuv.com  
ID: 8105073334



SOCIUNI  
Licenza 0082 del 15/12/2015



# VS

## CONDENSATE DRAINAGE SET

- Box
- ▶ Trays
- Universal Fitting
- Pipes
- Pump

## SCARICO CONDENSA

- Scatola
- ▶ Vaschette
- Raccordi
- Tubi
- Pompe



## INSTALLATION EXAMPLE

As we know, the air conditioner leaking water is not fault but it is normal for the condensate drain of the conditioner due to the hot and cold air exchange with the radiator. This range of accessories for the collection and drainage of the condensate of the external air-conditioning unit, helps us to solve this need.



## ESEMPIO DI INSTALLAZIONE

Come sappiamo, l'unità esterna di condizionamento che gocciola acqua non è rotta ma è il normale scarico della condensa causato dallo scambio di aria calda e fredda con il radiatore. Questa gamma di accessori per la raccolta e lo scarico della condensa dell'unità di climatizzazione esterna, ci aiuta a sistemare questo inconveniente.



# VS 110 VS 210



## CONDENSATE DRIP TRAY

Draining pipe: diam. 20 mm

## MATERIALS AND TREATMENT

**Material:** electro-galvanised steel

**Treatment:** epoxy resins in polyester for outdoor

**Colour:** Ral 9002

## BOX

**Pack:** nylon packaging

**Pieces:** 1 piece

## DIMENSIONS

VS 110

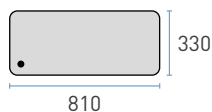

VS 210

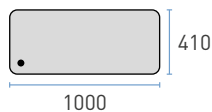

# VS 120 VS 220



## CONDENSATE DRIP TRAY

VS120 use with VS110

VS220 use with VS210

Fixing screw included

## MATERIALS AND TREATMENT

**Material:** electro-galvanised steel

**Treatment:** epoxy resins in polyester for outdoor

**Colour:** Ral 9002

## BOX

**Pack:** nylon packaging

**Pieces:** 1 couple

## DIMENSIONS

VS 120

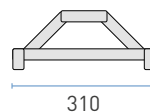

VS 220

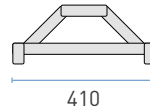

# VS 130 VS 230



## CONDENSATE DRIP TRAY

VS140 use with VS110

VS240 use with VS210

## MATERIALS AND TREATMENT

**Material:** electro-galvanised steel

**Treatment:** epoxy resins in polyester for outdoor

**Colour:** Ral 9002

## BOX

**Pack:** carton box

**Pieces:** 1 couple

## DIMENSIONS

VS 130

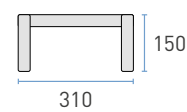

VS 230

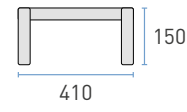

# VS 150 - VS 250

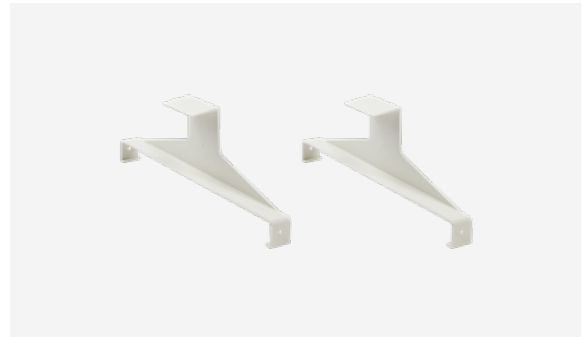

## CONDENSATE DRIP TRAY

- Tray for the collection of condensation water
- Made from rigid UV-stabilized plastic, 100% rust free
- Adjustable fixation to any kind of brackets
- Embedded water outlet for Ø 16 mm, 18 mm and 20 mm to connect to standard drain pipes and hoses
- The 2 hang supports are made of glass fibre reinforced plastic and are 100% rust free
- Inside surface of the tray is slightly recessed to lead the water to the outlet

## MATERIALS AND TREATMENT

**Material:** UV-stabilized plastic

**Colour:** white

## BOX

**Pack:** nylon packaging

**Pieces:** 1 piece

## DIMENSIONS

VS 150

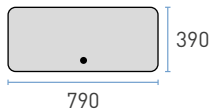

VS 250

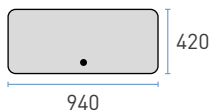

## CONDENSATE DRIP TRAY

- The 2 hang supports are made of glass fibre reinforced plastic and are 100% rust free

## MATERIALS AND TREATMENT

**Material:** UV-stabilized plastic

**Colour:** white

## DIMENSIONS

VS 150

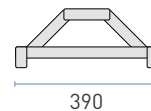

VS 250

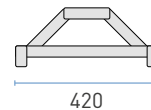

# RE 200



## HEATING CABLE

The series heating cable CNFx is used for the protection of pipes and to prevent freezing of the equipment used in the refrigeration industry and in hydraulic networks. It is equipped with a bimetal thermostat in the version  $+3^{\circ}\text{C} \pm 3^{\circ}\text{C} +8^{\circ}\text{C} \pm 3^{\circ}\text{C}$  (also available in the version  $+3^{\circ}\text{C} \pm 3^{\circ}\text{C} +13^{\circ}\text{C} \pm 3^{\circ}\text{C}$ ), which activates the circuit only when a specific temperature is reached, thus enabling significant energy savings. It is supplied already cut to measure and ready to use: the cable length cannot be shortened by the end user.

## RESISTENZA

Il cavo scaldante serie CNFx viene utilizzato per la protezione di tubi e per evitare il congelamento delle apparecchiature per la refrigerazione e reti idrauliche. È dotato di un termostato bimetallico  $+3^{\circ}\text{C} \pm 3^{\circ}\text{C} +8^{\circ}\text{C} \pm 3^{\circ}\text{C}$  (disponibile anche nella versione  $+3^{\circ}\text{C} \pm 3^{\circ}\text{C} +13^{\circ}\text{C} \pm 3^{\circ}\text{C}$ ) che attiva il circuito solamente in presenza di una data temperatura, tale da permettere un notevole risparmio energetico. Viene fornito già tagliato a misura e pronto all'uso: la lunghezza del cavo non può essere accorciata dall'utilizzatore finale.

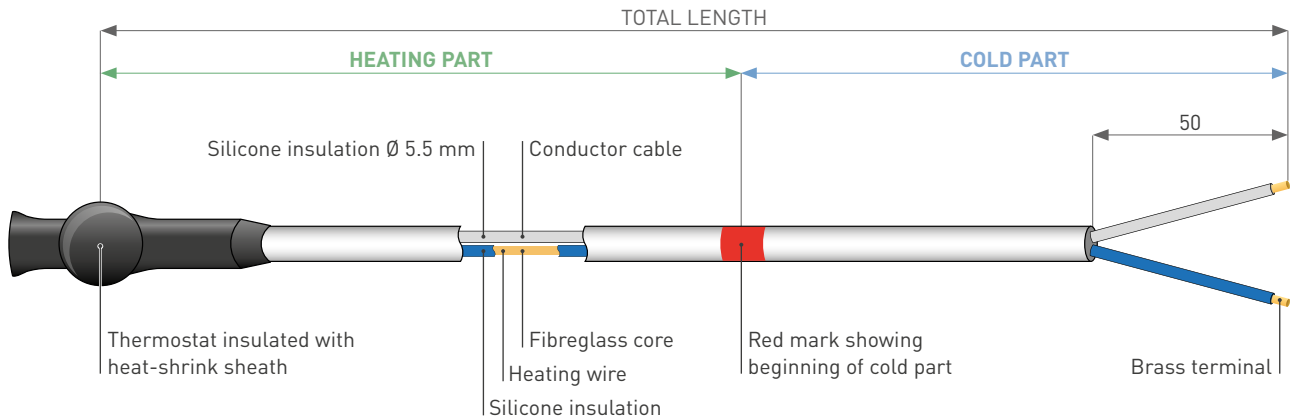

CODE	SUPPLY VOLTAGE	HEATING PART MM	COLD PART MM	TOTAL LENGTH
RE 200	220/240	1000	1000	2 mt
RE 300	220/240	2000	1000	3 mt
RE 400	220/240	3000	1000	4 mt
RE 500	220/240	4000	1000	5 mt

## Y 1616



**CONNECTION FOR  
CONDENSATE  
DRAINING PIPE**

### GENERAL DATA

**Input diameter:** 16  
**Output diameter:** 16  
**UVA resistant**  
**Resistant to:** -20°C / +40°C

### BOX

**Pack:** nylon packaging  
**Pieces per blister:** 10  
**Blister per case:** 10

## Y 1620



**CONNECTION FOR  
CONDENSATE  
DRAINING PIPE**

### GENERAL DATA

**Input diameter:** 16  
**Output diameter:** 20  
**UVA resistant**  
**Resistant to:** -20°C / +40°C

### BOX

**Pack:** nylon packaging  
**Pieces per blister:** 10  
**Blister per case:** 10

## Y 2020



**CONNECTION FOR CONDENSATE  
DRAINING PIPE**

### GENERAL DATA

**Input diameter:** 20  
**Output diameter:** 20  
**UVA resistant**  
**Resistant to:** -20°C / +40°C

### BOX

**Pack:** nylon packaging  
**Pieces per blister:** 10  
**Blister per case:** 10



# Y 105



## CONNECTION FOR CONDENSATE DRAINING PIPE

### GENERAL DATA

**Input diameter:** 16/18/20

**Output diameter:** 16/18/20

**UVA resistant**

**Resistant to** -20°C / +40°C

**Available accessories:**

**TSM 68/80** Metric drainage hose

**TU 16/18/20** Drainage hose

### BOX

**Pack:** Nylon blister

**Pieces per blister:** 10

**Blister per case:** 10

**Case dimension:** 250x350x150

**Pack average weight:** 2 kg

# TU



## SPIRALATED PIPE SMOOTH INSIDE

### GENERAL DATA

**Smooth inside**

**Resistant to** -20°C / +40°C  
(lab tests, no changes after 72 hours)

**Available accessories:**

Y 105 Y universal pipe fitting

Y 1616 pipe fitting

Y1620 pipe fitting

Y 2020 pipe fitting

### BOX

**Pack:** roll

**Meters:** 30

**Roll average dimension:**

400x400x200 mm

**Pack average weight:** 2.3 kg

### PALLET

**Pallet dimensions:**

120x80x100 cm

**Rolls per pallet:** 30

**Total pallet weight:** 100 kg

# TSM



## CORRUGATED PIPE WITH CONNECTION

### GENERAL DATA

**Corrugated drain pipe**

**Resistant to** -10°C / +40°C

**Available accessories:**

Y 105 Y universal pipe fitting

### BOX

**Pack:** carton box

**Meters:** 50

**Pack dimension:**

400x400x200 mm

### PALLET

**Pallet dimensions:**

120x80x100 cm

**Rolls per pallet:** 24

**Total pallet weight:** 100 kg

# TS 20 TR

# TS 20 MOR

# TS 20 DOR



## RIGID DRAIN PIPE

### GENERAL DATA

Rigid drain condensate pipe is an alternative solution to common flexible spiralated or corrugated pipes and warranty an high U.V. rays resistant and weight pressure resistance.

It could be installed on wall or inside wall and thanks to its accessories to connect and derivate could be quickly installed to all condition.

**Diameter:** 20 mm

**Length:** 2 meter

### BOX

**Pack:** carton box

**Meters:** 70

**Pieces per pack:** 35 bars

## CONNECTOR

### GENERAL DATA

Connector for rigid drain condensate pipe used to connect two pipe with O'ring.

### BOX

**Pack:** carton box

**Pieces per pack:** 20 pcs

## "T" DERIVATION

### GENERAL DATA

"T" derivation for rigid drain condensate pipe used to connect three pipes with O'ring.

### BOX

**Pack:** carton box

**Pieces per pack:** 20 pcs

## TS 20 COR



### 90° CORNER

#### GENERAL DATA

90° corner for rigid drain condensate pipe used to connect two pipes with a corner of 90° with O'ring.

#### BOX

**Pack:** carton box

**Pieces per pack:** 20 pcs

## TS 20 AOR



### 135° CORNER

#### GENERAL DATA

135° corner for rigid drain condensate pipe used to connect two pipes with a corner of 135° with O'ring.

#### BOX

**Pack:** carton box

**Pieces per pack:** 20 pcs

## TS 20 RU



### CONNECTOR

#### GENERAL DATA

Unique connector from rigid pipe to spiraled/flexible pipe Ø 14-16-18-20 mm.

#### BOX

**Pack:** carton box

**Pieces per pack:** 20 pcs

## TS 20 CF



### PIPE HOLDER CLIPS

#### GENERAL DATA

Rigid self-extinguishing PVC material VO.

#### BOX

**Pack:** carton box

**Pieces per pack:** 20 pcs

## TS 16 RU



### CONDENSATION CONNECTION SOFT-RIGID PIPE

#### GENERAL DATA

**Rigid pipe:** Ø 16 mm  
**Flexible pipe:** Ø 14-16-18-20 mm

#### BOX

**Pack:** carton box  
**Pieces per pack:** 20 pcs

## TS 18 RU



### CONDENSATION CONNECTION SOFT-RIGID PIPE

#### GENERAL DATA

**Rigid pipe:** Ø 18 mm  
**Flexible pipe:** Ø 14-16-18-20 mm

#### BOX

**Pack:** carton box  
**Pieces per pack:** 20 pcs

## TS 25 RU



### CONDENSATION CONNECTION SOFT-RIGID PIPE

#### GENERAL DATA

**Rigid pipe:** Ø 25 mm  
**Flexible pipe:** Ø 14-16-18-20 mm

#### BOX

**Pack:** carton box  
**Pieces per pack:** 20 pcs

## TS 32 RU



### CONDENSATION CONNECTION SOFT-RIGID PIPE

#### GENERAL DATA

**Rigid pipe:** Ø 32 mm  
**Flexible pipe:** Ø 14-16-18-20 mm

#### BOX

**Pack:** carton box  
**Pieces per pack:** 20 pcs

## Y 106



### SIPHONE

#### GENERAL DATA

The siphon is realized to avoid problem of bad odours coming back from drain condensate pipe. Simple and practical accessory, could be easily connected with all drain condensate pipes. It's made of rigid and transparent PVC to check it quickly. Thanks to its dimension it could be places inside duct also.

Il sifone è stato realizzato per evitare il ritorno dei cattivi odori provenienti dal tubo di scarico condensa. Semplice e funzionale, può essere agevolmente collegato a tutti i tubi di scarico. In PVC rigido trasparente per consentirne rapida ispezione. Grazie alle sue contenute dimensioni può essere collocato anche in canalina.

## Y 107



### INSPECTABLE CONDENSATION WATER SIPHON

#### GENERAL DATA

Avoids bad smells!  
Can be installed vertically and horizontally.  
Various connection combinations possible.  
Inspectable.

**Input pipe connection:** Ø 20 mm

**Output pipe connection:** Ø 16-18 mm

#### BOX

**Pack:** carton box

**Pieces per pack:** 20 pcs



VERTICAL INSTALLATION



HORIZONTAL INSTALLATION



A large, stylized purple letter 'D' is positioned in the upper right quadrant of the image. The background is a light gray color, featuring several dark gray, curved, geometric shapes that resemble architectural elements or abstract forms. The shapes are layered and create a sense of depth and movement. The letter 'D' is a simple, bold, sans-serif font with a thick stroke.

# UCTS

DUCTS  
CANALINE

Rodigas<sup>®</sup>  
SRL 

## BM - BC



**Code:** BM 60 - BC 60

**Description:** raceway base with lid of 2 ml. bars

**Bearing capacity:** 1 ml

**Material:** V0 self-extinguishing PVC

**Operating temperature:**  
-20° +60° C

**Pack size:** BC 60 - 24 pcs,  
BC 80 - 16 pcs, BC 120 - 8 pcs

### DIMENSIONS

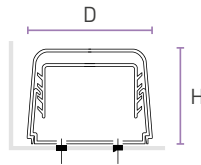

TYPE	L	H
BC 60	60	45
BC 80	80	60
BC 120	110	75

## GF



**Code:** GF 60 - GF 80

**Description:** flexible joint

**Bearing capacity:** 1 pc

**Material:** V0 self-extinguishing PVC

**Operating temperature:**  
-20° +60° C

**Pack size:** GF 60 - 6 pcs, GF 80 - 4 pcs

## CP



**Code:** CP 60 - CP 80 - CP 120

**Description:** flat curve

**Bearing capacity:** 1 pc

**Material:** V0 self-extinguishing PVC

**Operating temperature:**  
-20° +60° C

**Pack size:** CP 60 - 10 pcs,  
CP 80 - 8 pcs, CP 120 - 6 pcs

## DT



**Code:** DT 80 - DT 120

**Description:** T diversion

**Bearing capacity:** 1 pc

**Material:** V0 self-extinguishing PVC

**Operating temperature:**  
-20° +60° C

**Pack size:** DT 80 - 1 pc,  
DT 120 - 2 pc

## AI



**Code:** AI 60 - AI 80 - AI 120

**Description:** 90° external angle

**Bearing capacity:** 1 pc

**Material:** V0 self-extinguishing PVC

**Operating temperature:**  
-20° +60° C

**Pack size:** AI 60 - 8 pcs,  
AI 80 - 6 pcs, AI 120 - 4 pcs

## CM



**Code:** CM 60 - CM 80 - CM 120  
**Description:** wall curve  
**Bearing capacity:** 1 pc  
**Material:** VO self-extinguishing PVC  
**Operating temperature:** -20° +60° C  
**Pack size:** CM 60 - 9 pcs, CM 80 - 6 pcs, CM 120 - 4 pcs

## TT



**Code:** TT 60 - TT 80  
**Description:** terminal plug  
**Bearing capacity:** 1 pc  
**Material:** VO self-extinguishing PVC  
**Operating temperature:** -20° +60° C  
**Pack size:** TT 60 - 12 pcs, TT 80 - 9 pcs

## PM



**Code:** PM 60 - PM 80  
**Description:** wall passage  
**Bearing capacity:** 1 pc  
**Material:** VO self-extinguishing PVC  
**Operating temperature:** -20° +60° C  
**Pack size:** PM 60 - 10 pcs, PM 80 - 8 pcs

## AE



**Code:** AE 60 - AE 80 - AE 120  
**Description:** 90° external angle  
**Bearing capacity:** 1 pc  
**Material:** VO self-extinguishing PVC  
**Operating temperature:** -20° +60° C  
**Pack size:** AE 60 - 12 pcs, AE 80 - 9 pcs, AE 120 - 6 pcs

## RI



**Code:** RI 60 - RI 80  
**Description:** reduction  
**Bearing capacity:** 1 pc  
**Material:** VO self-extinguishing PVC  
**Operating temperature:** -20° +60° C  
**Pack size:** RI 60 - 12 pcs, RI 80 - 8 pcs

## ST



**Code:** ST 60 - ST 80 - ST 120  
**Description:** pipe fixing brackets  
**Bearing capacity:** 1 pc  
**Material:** VO self-extinguishing PVC  
**Operating temperature:** -20° +60° C  
**Pack size:** ST 60 - 30 pcs, ST 80 - 30 pcs, ST 120 - 20 pcs

## GC



**Code:** GC 60 - GC 80 - GC 120  
**Description:** lid joint  
**Bearing capacity:** 1 pc  
**Material:** VO self-extinguishing PVC  
**Operating temperature:** -20° +60° C  
**Pack size:** GC 60 - 30 pcs, GC 80 - 30 pcs, GC 120 - 20 pcs

## VS



**Code:** VS 60-80

**Description:** left vertical angle

**Material:** VO self-extinguishing PVC

**Operating temperature:**  
-20° +60° C

**Pack size:** 4 pcs

## VD



**Code:** VD 60-80

**Description:** right vertical angle

**Material:** VO self-extinguishing PVC

**Operating temperature:**  
-20° +60° C

**Pack size:** 4 pcs

## IR



**Code:** IR 60-80

**Description:** adjustable internal angle 80°-105°

**Material:** VO self-extinguishing PVC

**Operating temperature:** -20° +60° C

**Pack size:** 4 pcs

## PR



**Code:** PR 60-80

**Description:** adjustable plane curve 65°-130°

**Pack size:** 6 pcs

## ER



**Code:** ER 60-80

**Description:** adjustable external angle 70°-120°

**Pack size:** 8 pcs

## BC30



**Code:** BC30

**Description:** duct with enveloping top

**Material:** VO self-extinguishing PVC

**Operating temperature:** -20° +60° C

**Pack size:** 2 m

## RC30



**Code:** RC30

**Description:** reduced connection

**Material:** VO self-extinguishing PVC

**Operating temperature:** -20° +60° C

**Pack size:** 20 pcs

## TT30



**Code:** TT30

**Description:** terminal plug

**Material:** VO self-extinguishing PVC

**Operating temperature:** -20° +60° C

**Pack size:** 20 pcs

## AE30



**Code:** AE30

**Description:** 90° external angle

**Material:** VO self-extinguishing PVC

**Operating temperature:** -20° +60° C

**Pack size:** 20 pcs

## CP30



**Code:** CP30

**Description:** flat curve

**Material:** VO self-extinguishing PVC

**Operating temperature:** -20° +60° C

**Pack size:** 20 pcs

## AI30



**Code:** AI30

**Description:** 90° internal angle

**Material:** VO self-extinguishing PVC

**Operating temperature:** -20° +60° C

**Pack size:** 20 pcs

## GC30



**Code:** GC30

**Description:** lid joint

**Material:** VO self-extinguishing PVC

**Operating temperature:** -20° +60° C

**Pack size:** 20 pcs





NOT  
PROD

# HER UCTS

OTHER PRODUCTS  
ALTRI PRODOTTI

Rodigas<sup>®</sup>  
SRL 

# OUTDOOR UNITS GUARDS

## MATERIALS AND TREATMENT

**Colour:** outdoor epoxy resin in ral 9002

**Material:** electro galvanized steel  
outdoor epoxy resin

## ACCESSORIES

available on request backside door and  
condensing tray



### Right side

keylock included in the kit door for inspection  
and cleaning

### EXTERNAL DIMENSION

CODE	HEIGHT (mm)	WIDTH (mm)	DEPTH (mm)
MA101	800	1000	500
MA102	900	1000	600
MA103	1000	1200	600
MA104	1200	1200	600
MA105	1400	1200	650
MA106	1600	1200	650

### INTERNAL DIMENSION

CODE	HEIGHT (mm)	WIDTH (mm)	DEPTH (mm)
MA101	790	930	480
MA102	890	930	580
MA103	990	1130	580
MA104	1190	1130	580
MA105	1390	1130	630
MA106	1590	1130	630



## MA 401 SNOW COVER

### MATERIALS AND TREATMENT

**Colour:** outdoor epoxy resin in ral 9002

**Material:** electro galvanized steel  
outdoor epoxy resin

### DIMENSIONS

**Cover length:** 1100 mm

**Cover width:** 560 mm

### SNOW COVER

Made in electro-galvanized and painted steel for the protection of external air conditioning units from snow and rain. It can be used on different types of machinery, it is supplied in assembly kit.

On the upper part, there are pre-perforations to allow the possible passage of the pipes.

### SNOW COVER

Realizzata in acciaio elettrozincato e verniciato per la protezione delle unità esterne di condizionamento dalla neve e pioggia utilizzabile su diverse tipologie di macchinari, viene fornita in kit di montaggio. Sulla parte superiore, sono presenti delle pre-forature per permettere l'eventuale passaggio delle tubazioni.



### Bracket details

Pre-drilled hole on the top for pipe connection

## FS 400

FIXING KIT FOR DUCT



### GENERAL DATA

**Screw size:** M5x35  
self-tapping

**Diameter:** 12 mm  
crosshead

**Block size:** M6x30

### BOX

**Pack:** thermoformed blister

**Pieces:** 300+300

**Blister dimension:**  
250x210x40 mm

## FS 300

FIXING KIT FOR CHEMICAL ANCHORING



### GENERAL DATA

**Screw size:** threaded bar  
M8x120 + bolts and nuts

**Block size:** M8x80

### BOX

**Pack:** nylon blister

**Pieces:** 4 series

## FS 101

FIXING KIT FOR SUPPORTS



### GENERAL DATA

**Screw size:** M8x80  
galvanized hexagonal  
head lag screw

**Block size:** M12x70

**Washer size:** M8x24

### BOX

**Pack:** nylon blister

**Pieces per pack:** 4+4+4

## FS 800

FIXING KIT FOR INSULATING LAYER



### DESCRIPTION

Fixing kit for the insulating layer.  
This practical kit is suitable for the installation of the brackets of the standards sliding and sliding lines on the buildings covered with insulating coats.

Kit di fissaggio per lo strato isolante.  
Questo pratico kit è adatto per l'installazione delle staffe delle linee scorrevoli e scorrevoli standard sugli edifici coperti con strati isolanti.

### TECHNICAL CHARACTERISTICS

**Srew:** galvanized threaded rod 330×8mm  
**Spacer:** 50×2mm in PVC  
**Accessories:** PP washer and components

### BOX

**Pack:** nylon blister  
**Pieces:** 4 series + 2 feet

## FA 101 - FA 102

ADHESIVE INSULATING BAND



### TECHNICAL CHARACTERISTICS

**FA 101 colour:** black  
**FA 102 colour:** white  
**Classification of reaction to fire:** Class 1  
**Coefficient of thermal conductivity at 0°C:**  $\lambda$  0,034  
**Steam diffusion resistance coefficient:**  $\mu$  11.268  
**Operating temperature:** -40°C a +105°C  
**Thickness:** 3 mm  
**Width:** 50 mm  
**Length:** 10 m

### BOX

Single packaging in transparent cellophane envelope  
**Carton pack:** 43×43×21 cm  
**Pack content:** 24 rolls



## CPR

### TAPS COVER



#### DESCRIPTION

Universal tap covers for outdoor units. Designed to reduce the formation of condensation on the outside of the taps when using the air conditioner.

Very practical during maintenance thanks to the quick Velcro closure.

#### DESCRIZIONE

Coprirubinetti universali per unità esterne. Studiati per ridurre il formarsi di condensa nella parte esterna dei rubinetti durante l'uso del condizionatore.

Molto pratici in fase di manutenzione grazie all'chiusura rapida in velcro.

#### TECHNICAL CHARACTERISTICS

**Material:** foam

**Colour:** beige

#### BOX

**Pack:** blister in nylon

**Pieces per blister:** 10 Pcs

**Multi-pack:** carton box

**Blister per case:** 100 Pcs

## CT

### PROTECTIVE COVER FOR EXTERNAL AIR-CONDITIONING UNITS WHEN NOT OPERATING



#### DESCRIPTION

This hood protects the external unit of the air conditioner from atmospheric agents during times of inactivity, representing the ideal solution in case of prolonged periods of absence.

#### DESCRIZIONE

Questa cappottina protegge l'unità esterna del condizionatore dagli agenti atmosferici durante i momenti di inutilizzo rappresentando la soluzione ideale in caso di prolungati periodi di assenza.

#### TECHNICAL CHARACTERISTICS

Calendered self-extinguishing PVC with 220.0 micron thickness.

UV-resistant gray fabric.

Fully sewn and strengthened in the internal seams

Sling in fabric for lateral closure "tube entry".

Gray polyester closing cable diam. 0.2mm.

Anti-condensation ventilation system.

CODE	HEIGHT	WIDTH	DEPTH
CT 001	55 cm	70 cm	30 cm
CT 002	60 cm	80 cm	30 cm
CT 003	70 cm	86 cm	36 cm
CT 004	85 cm	95 cm	40 cm

## EB 101 LINE SET BENDER

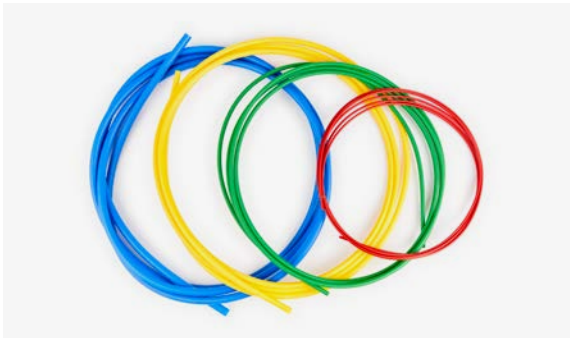

### DESCRIPTION

The tool that you need to bend linesets when installing split systems.

Easiest way to bend twin tubes without damaging their insulation.

Reusable after cleaning!

No need for springs or heavy equipment!

Only for soft copper.

### BOX

**Pack:** nylon blister

**Pieces:** 1 set contains the 4 different colours

**Box:** 1 box contains 10 sets

EB 101	Diameter	Fits tube	Length
Red	4 mm	1/4"	4 m
Green	6 mm	3/8"	4 m
Yellow	9 mm	1/2"	4 m
Blue	12 mm	5/8"	4 m

## EB 201 LINE SET BENDER



### DESCRIPTION

The tool that you need to bend linesets when installing split systems.

Easiest way to bend twin tubes without damaging their insulation.

Reusable after cleaning!

No need for springs or heavy equipment!

Only for soft copper.

### BOX

**Pack:** nylon blister

**Pieces:** 1 piece

**Box:** 1 box contains 10 pieces

EB 201	Diameter	Fits tube	Length
White	16 mm	3/4"	4 m

# ALUMINIUM ROOF INLET

## DESCRIPTION

To cover the hole on the roof made to pass through linesets, that are connected to an outdoor unit.

High thermal stability.

Good chemical resistance.

Excellent resistance to weathering and ageing.

Assembly by stainless steel screw (supplied).

Questi accessori, si utilizzano per proteggere dalle intemperie i fori realizzati sulle coperture per passare con le tubazioni in rame che collegano l'unità esterne a quelle interne.

Elevata stabilità termica.

Eccellente resistenza agli agenti atmosferici e all'invecchiamento.

Montaggio mediante vite in acciaio inossidabile (in dotazione).

Sistema di anti taglio delle tubazioni in plastica.



## DIMENSIONS AND LOADING CAPACITY

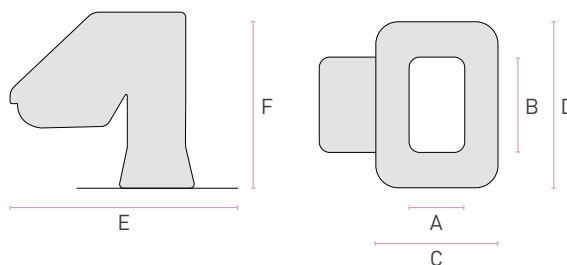

## GENERAL DATA

**Material:** Aluminium

**Colour:** RAL 9002 - RAL 7016 MATT

**Pack:** carton box

**Pieces:** 1 piece



MODEL	UT100	UT200	UT400
Material	Aluminium	Aluminium	Aluminium
Inside dimensions: AxB	80x80 mm	125x125 mm	125x250 mm
Outside dimensions: CxD	260x260 mm	360x360 mm	360x490 mm
Outside dimensions: ExF	290x240 mm	520x465 mm	520x465 mm
MOQ Packing	1 pc	1 pc	1 pc
Pallet	30 pcs	30 pcs	30 pcs



# PLASTIC ROOF INLET

## DESCRIPTION

To cover the hole on the roof made to pass through linesets, that are connected to an outdoor unit.

High thermal stability.

Good chemical resistance.

Excellent resistance to weathering and ageing.

Assembly by stainless steel screw (supplied).

## DIMENSIONS AND LOADING CAPACITY

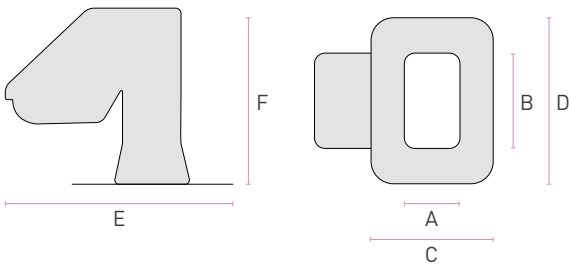

MODEL	UT300	UT500
Material	Pvc	Pvc
Inside dimensions: AxB	125x125 mm	125x250 mm
Outside dimensions: CxD	360x360 mm	360x490 mm
Outside dimensions: ExF	522x420 mm	522x420 mm
MOQ Packing	1 pc	1 pc
Pallet	30 pcs	32 pcs

Questi accessori, si utilizzano per proteggere dalle intemperie i fori realizzati sulle coperture per passare con le tubazioni in rame che collegano l'unità esterne a quelle interne.

Elevata stabilità termica.

Eccellente resistenza agli agenti atmosferici e all'invecchiamento.

Montaggio mediante vite in acciaio inossidabile (in dotazione).

Sistema di anti taglio delle tubazioni in plastica.

## GENERAL DATA

**Material:** UV-stabilized plastic

**Colour:** RAL 9002

**Pack:** carton box

**Pieces:** 1 piece



Fixing details



FR  
FO

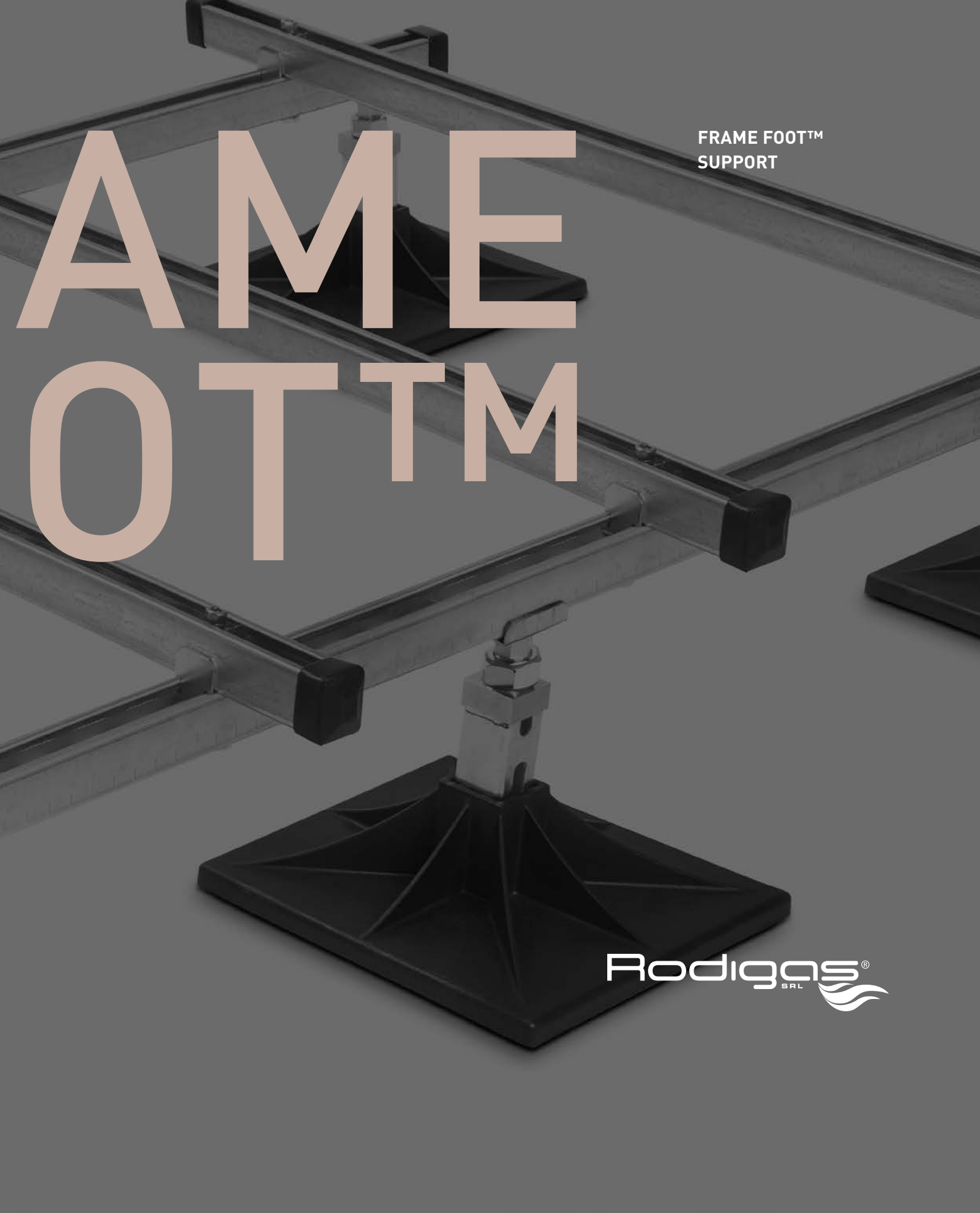

# FRAME FOOT™ SUPPORT

FRAME FOOT™  
SUPPORT

Rodigas®  
SRL 



# FT 200

## FRAME FOOT™ SUPPORT

### DESCRIPTION

Heavy-duty supporting system for use on flat or sloped (optional) surfaces.

### STEEL FRAME

Manufactured from galvanised strut channels.  
All steel connections, screws and clamps are galvanised.  
Plastic end caps included.  
Height-adjustable from 295 mm up to 415 mm with M24 screw.  
Option from 745 mm to 865 mm.  
Easily adjustable, even after installation.  
Handy moveable bracket for 90° mounting channels.  
Special dimensions available on request.

### PLASTIC FOOT

High-impact composite material:  
composite plastics  
Equipped with anti-vibration mat  
UV-resistant  
Standard colour: black  
Working temperature: -40°C to +80°C  
Max. load per foot: 240 kg

### GENERAL DATA

**Frame dimensions:** 1000×1200 mm  
**Foot dimensions:** 300×300 mm  
**Max load capacity\*:** 500 kg  
**Max spreaded load capacity\*:** 500 kg / m<sup>2</sup>

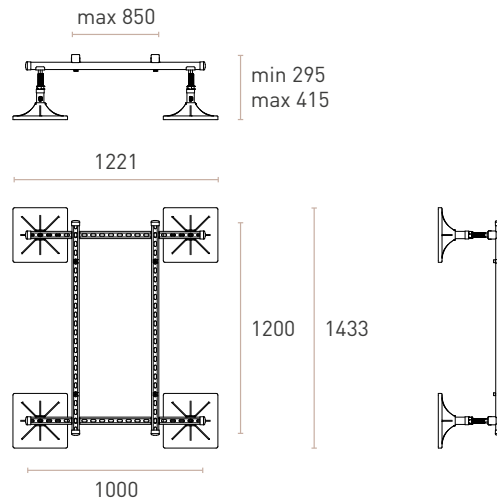

EASY REGULATION



QUICK ASSEMBLING

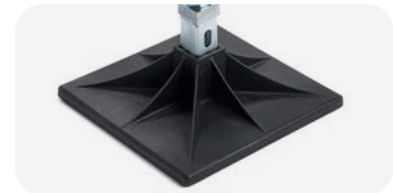

FEET + ANTIVIBRATION MATS

# FT 300

## FRAME FOOT™ SUPPORT

### DESCRIPTION

Heavy-duty supporting system for use on flat or sloped (optional) surfaces.  
Height-adjustable from 295 mm to 415 mm (even after installation).

### STEEL FRAME

Manufactured from galvanised strut channels.

All steel connections, screws and clamps are galvanised.

Plastic end caps included.

Height-adjustable from 295 mm up to 415 mm with M24 screw.

Option from 745 mm to 865 mm.

Easily adjustable, even after installation.

Handy moveable bracket for 90° mounting channels.

Special dimensions available on request.

### PLASTIC FOOT

High-impact composite material:  
composite plastics

Equipped with anti-vibration mat

UV-resistant

Standard colour: black

Working temperature: -40°C to +80°C

Max. load per foot: 240 kg

### GENERAL DATA

**Frame dimensions:** 2221×1433 mm

**Foot dimensions:** 300×300 mm

**Max load capacity\*:** 1040 kg

**Max spreaded load capacity\*:** 500 kg / m<sup>2</sup>

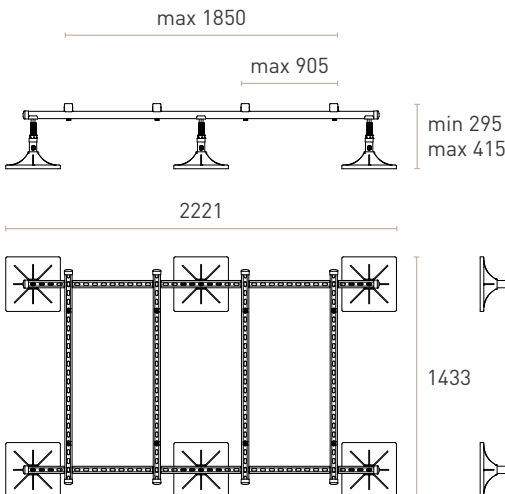

**SURFACE LOAD TABLE - FOOT SURFACE 300×300 mm\***

Load per foot - kg/pc	10	20	30	40	50	60	70	80	90	100	110	120
Load per foot - kN/m <sup>2</sup> on the ground/flats roofs	1,90	2,18	3,27	4,36	5,45	6,54	7,63	8,72	9,81	10,90	11,99	13,08

# FT 400

## FRAME FOOT™ SUPPORT

### DESCRIPTION

Heavy-duty supporting system for use on flat or sloped (optional) surfaces.

### STEEL FRAME

Manufactured from galvanised strut channels.

All steel connections, screws and clamps are galvanised.

Plastic end caps included.

Height-adjustable from 295 mm up to 415 mm with M24 screw.

Option from 745 mm to 865 mm.

Easily adjustable, even after installation.

Handy moveable bracket for 90° mounting channels.

Special dimensions available on request.

### PLASTIC FOOT

High-impact composite material: composite plastics

Equipped with anti-vibration mat

UV-resistant

Standard colour: black

Working temperature: -40°C to +80°C

Max. load per foot: 240 kg

### GENERAL DATA

**Frame dimensions:** 3000×1200 mm

**Foot dimensions:** 300×300 mm

**Max load capacity\*:** 1620 kg

**Max spreaded load capacity\*:** 500 kg / m<sup>2</sup>

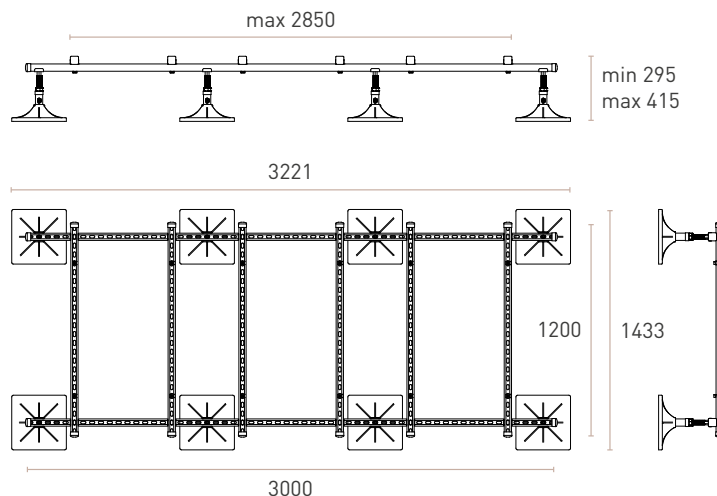

EASY REGULATION



QUICK ASSEMBLING

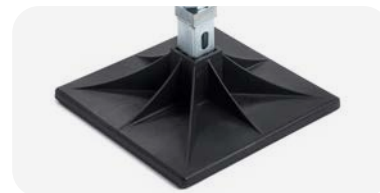

FEET + ANTIVIBRATION MATS

## FT 500 EXTENSION MODULE



### DESCRIPTION

Extension module for FT 200, FT 300, FT 400.  
Height-adjustable from 295 mm to 415 mm.  
Channels connector included.

### GENERAL DATA

**Frame dimensions:** 1111×1433 mm  
**Foot dimensions:** 300×300 mm  
**Max load capacity\*:** 500 kg  
**Max spreaded load capacity\*:** 500 kg/m<sup>2</sup>

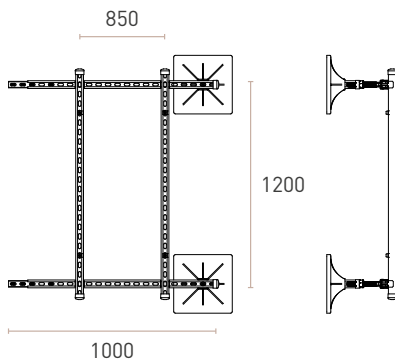

\* The maximum load / spread load capacity is expressed without taking into account any safety parameter or factor. It is the customer's responsibility to choose and use appropriate tools and fixing materials which ensure that the final installation is in compliance with all national, state, local and environmental regulations. Check the safety parameters that are appropriate for your intended use and contact us if necessary.

## FT 100 AIR DUCTS SUPPORT



### DESCRIPTION

H-frame to support air ducts.  
Easily adjustable, even after installation.  
Galvanized steel elements based on common struts channels.  
Other dimensions available on request.

### GENERAL DATA

**Dimensions:** 952×625×310 mm  
**Height-adjustable:** from 240 mm to 600 mm  
**Foot dimensions:** 300×300 mm  
**Max load capacity\*:** 480 kg  
**Max spreaded load capacity\*:** 500 kg/m<sup>2</sup>

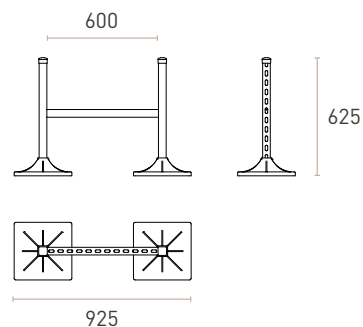

# RUBBER FIX

## DESCRIPTION

Rubber black floor supports guarantee a practical versatile and environmentally friendly solution. Supports are made of black SBR recycled rubber that warranty an high decrement of vibrations and durability. External unit, or other utilities, can be fixed through aluminum channel recessed into support. Support has also practical hole to fix it to ground. It's supplied with fixing components.

I supporti a pavimento in gomma nera garantiscono una soluzione pratica, versatile ed attenta all'ambiente. I supporti sono infatti realizzati con gomma riciclata SBR che garantisce un'elevata riduzione delle vibrazioni e durata nel tempo. Il fissaggio della motocondensante (o eventuali altre utenze) è garantito dal profilo di alluminio annegato nel supporto stesso. Il supporto è inoltre provvisto di predisposizione per il fissaggio a terra e viene fornito completo di viti.

## GENERAL DATA

**Foot material:** SBR recycled rubber

**Profile material:** aluminium

**Profile dimension:** 21x22 mm

**Fixing screw:** M10x30mm

**Colour:** black



Other products available on the dedicated catalog.



## DIMENSIONS AND LOADING CAPACITY

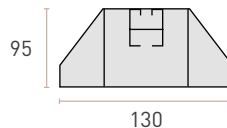

RB 250



RB 400



RB 600



RB 100



Code	Dimensions	Lenght	Load capacity
RB 250	130x95 mm	250 mm	120
RB 400	130x95 mm	400 mm	180
RB 600	130x95 mm	600 mm	300
RB 100	130x95 mm	1000 mm	350

# RUBBER FIX



## DIMENSIONS AND LOADING CAPACITY

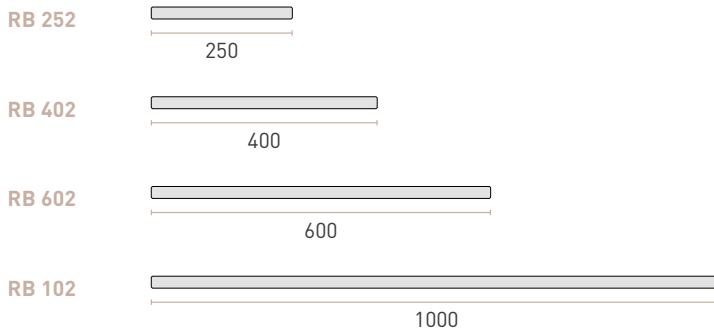
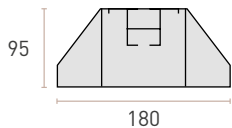

Code	Dimensions	Length	Load capacity
RB 252	180×95 mm	250 mm	120 kg
RB 402	180×95 mm	400 mm	180 kg
RB 602	180×95 mm	600 mm	300 kg
RB 102	180×95 mm	1000 mm	350 kg

## DESCRIPTION

Rubber black floor supports guarantee a practical versatile and environmentally friendly solution. Supports are made of black SBR recycled rubber that warranty an high decrement of vibrations and durability. External unit, or other utilities, can be fixed through aluminum channel recessed into support. Support has also practical hole to fix it to ground. It's supplied with fixing components.

I supporti a pavimento in gomma nera garantiscono una soluzione pratica, versatile ed attenta all'ambiente. I supporti sono infatti realizzati con gomma riciclata SBR che garantisce un'elevata riduzione delle vibrazioni e durata nel tempo. Il fissaggio della motocondensante (o eventuali altre utenze) è garantito dal profilo di alluminio annegato nel supporto stesso. Il supporto è inoltre provvisto di predisposizione per il fissaggio a terra e viene fornito completo di viti.

## GENERAL DATA

**Foot material:** SBR recycled rubber  
**Profile material:** aluminium  
**Profile dimension:** 42×22 mm  
**Fixing screw:** M10×30mm  
**Colour:** black



# RUBBER FIX

## DESCRIPTION

Rubber black floor supports guarantee a practical versatile and environmentally friendly solution. Supports are made of black SBR recycled rubber that warranty an high decrement of vibrations and durability. External unit, or other utilities, can be fixed through aluminum channel recessed into support. Support has also practical hole to fix it to ground. It's supplied with fixing components.

I supporti a pavimento in gomma nera garantiscono una soluzione pratica, versatile ed attenta all'ambiente. I supporti sono infatti realizzati con gomma riciclata SBR che garantisce un'elevata riduzione delle vibrazioni e durata nel tempo. Il fissaggio della motocondensante (o eventuali altre utenze) è garantito dal profilo di alluminio annesso nel supporto stesso. Il supporto è inoltre provvisto di predisposizione per il fissaggio a terra e viene fornito completo di viti.



## DIMENSIONS AND LOADING CAPACITY

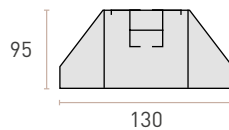

RB 253



RB 403



RB 603

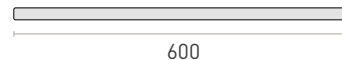

RB 103

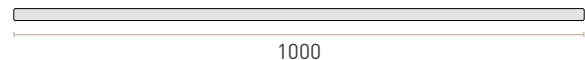

## GENERAL DATA

**Foot material:** SBR recycled rubber

**Profile material:** aluminium

**Profile dimension:** 42×22 mm

**Fixing screw:** M10×30mm

**Colour:** black

Code	Dimensions	Length	Load capacity
RB 253	130×95 mm	250 mm	120 kg
RB 403	130×95 mm	400 mm	180 kg
RB 603	130×95 mm	600 mm	300 kg
RB 103	130×95 mm	1000 mm	350 kg

# RUBBER RISER



## DESCRIPTION

The extension riser is made in the same material as the Rubber fix. This component simplifies the installation, when is necessary to elevate the standard systems.

## GENERAL DATA

**Riser material:** SBR recycled rubber  
**Colour:** black

## DIMENSIONS

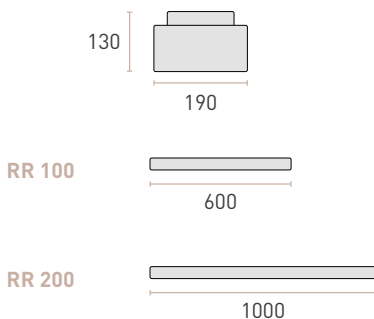

# HEXAHERAL RUBBER BLOCKS



## DESCRIPTION

Hexahedral rubber blocks is a perfect solution to fix pipes, canalization, and others stuff to preserve the roof covers Available in two different size.

## GENERAL DATA

**Riser material:** SBR recycled rubber  
**Colour:** black

## DIMENSIONS

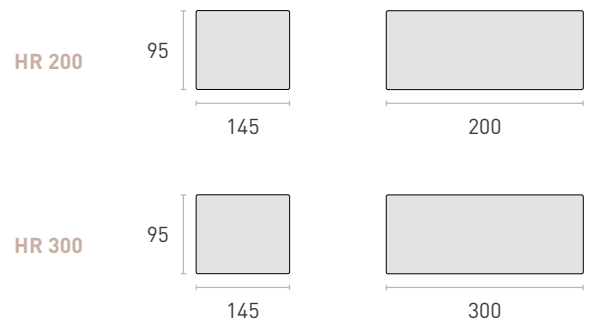

Rodigas Srl reserves the right to make changes to the products described in the catalogue at any time without notice. All data presented herein are indicative and not binding.

Rodigas Srl reserves the right to make changes to the products described in the catalogue at any time without notice.  
All data presented herein are indicative and not binding.

Rodigas Srl si riserva di apportare variazioni ai prodotti del presente catalogo, in qualsiasi momento, anche senza preavviso.  
Tutti i dati qui riportati sono indicativi e non vincolanti.



RODIGAS.IT

Via Giacomelli, 10  
35010 Limena  
Padova (Italy)

T +39 049 884 00 56  
F +39 049 884 00 60  
info@rodigas.it